

## Main view

## 0303413 PZN-plus 125-2

- i** Please note that the drawing shown is a view of the basic product. Individual product variants are supplemented by the following drawings. Please also take note of the article's catalog data sheet here.

Main view 0303413 PZN-plus 125-2 (PDF)

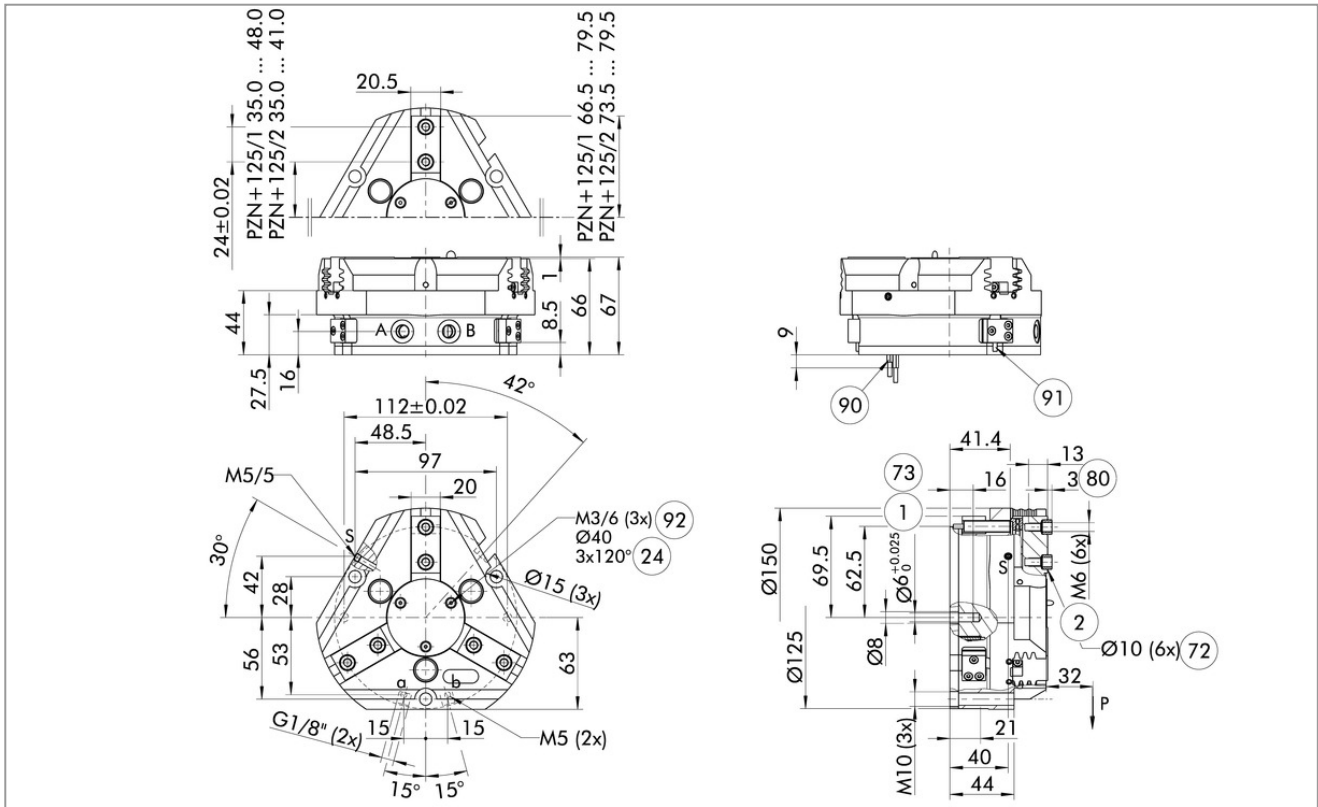

The drawing shows the gripper in the basic version with closed jaws, without dimensional consideration of the options described below.

- A, a Main / direct connection, gripper opening
- B, b Main / direct connection, gripper closing
- S Air purge connection
- ① Gripper connection
- ② Finger connection
- ②④ Bolt circle
- ⑦② Fit for centering sleeves
- ⑦③ Fit for centering pins
- ⑧① Depth of the centering sleeve hole in the counter part

- ⑨0 Sensor MMS 22..
- ⑨1 Sensor IN ...
- ⑨2 Thread below the cover for fastening external attachments