

Assembly and Operating Manual

PZN-plus

3-Finger Centric Gripper



Imprint

Copyright:

This manual is protected by copyright. The author is SCHUNK GmbH & Co. KG. All rights reserved. Any reproduction, processing, distribution (making available to third parties), translation or other usage - even excerpts - of the manual is especially prohibited and requires our written approval.

Technical changes:

We reserve the right to make alterations for the purpose of technical improvement.

Document number: 389374

Version: 10.00 | 09/04/2019 | en

© SCHUNK GmbH & Co. KG

All rights reserved.

Dear Customer,

thank you for trusting our products and our family-owned company, the leading technology supplier of robots and production machines.

Our team is always available to answer any questions on this product and other solutions. Ask us questions and challenge us. We will find a solution!

Best regards,

Your SCHUNK team

SCHUNK GmbH & Co. KG
Spann- und Greiftechnik

Bahnhofstr. 106 – 134
D-74348 Lauffen/Neckar

Tel. +49-7133-103-0

Fax +49-7133-103-2399

info@de.schunk.com

schunk.com

Table of contents

1	General	6
1.1	About this manual	6
1.1.1	Presentation of Warning Labels	6
1.1.2	Definition of Terms	6
1.1.3	Applicable documents	7
1.1.4	Sizes	7
1.1.5	Variants.....	7
1.2	Warranty	8
1.3	Scope of delivery	8
1.3.1	Accessories kit	8
1.4	Accessories	9
1.4.1	Sealing kit	9
2	Basic safety notes	10
2.1	Intended use.....	10
2.2	Not intended use.....	10
2.3	Constructional changes	10
2.4	Spare parts	10
2.5	Gripper fingers	11
2.6	Environmental and operating conditions	11
2.7	Personnel qualification.....	11
2.8	Personal protective equipment.....	12
2.9	Notes on safe operation.....	12
2.10	Transport.....	13
2.11	Malfunctions.....	13
2.12	Disposal	13
2.13	Fundamental dangers.....	14
2.13.1	Protection during handling and assembly	14
2.13.2	Protection during commissioning and operation	14
2.13.3	Protection against dangerous movements.....	15
2.13.4	Protection against electric shock.....	15
2.14	Notes on particular risks.....	16
3	Technical data	18
4	Design and description	19
4.1	Design	19
4.2	Description	19
5	Assembly	20
5.1	Installing and connecting.....	20
5.2	Connections.....	21
5.2.1	Mechanical connection.....	21

5.2.2	Pneumatic connection	25
5.3	Mounting the sensor	26
5.3.1	Overview of sensors	26
5.3.2	Setting dimensions for magnetic switches	27
5.3.3	Switch-off hysteresis for magnetic switches	29
5.3.4	Turn control cam	29
5.3.5	Mounting MMS 22 magnetic switch.....	30
5.3.6	Mounting MMS 22-PI1 programmable magnetic switch.....	31
5.3.7	Mounting programmable MMS 22-PI2 magnetic switch.....	32
5.3.8	Mounting programmable MMS-P 22 magnetic switch.....	33
5.3.9	Mounting inductive proximity switch IN 80	34
5.3.10	Mounting the reed switch RMS 80	36
5.3.11	Mounting flexible position sensor FPS	38
5.3.12	Mounting the analog position sensor APS-M1	39
5.3.13	Mounting the analog position sensor APS-Z80.....	40
5.3.14	Mounting the radio system RSS-R1/T2.....	42
5.3.15	Mounting FMS force-measuring jaw	42
6	Troubleshooting	43
6.1	Product is not moving.....	43
6.2	Product is not executing the complete stroke	43
6.3	Product opens or closes abruptly	43
6.4	Gripping force is dropping.....	44
6.5	Product does not achieve the opening and closing times	44
6.6	Programmable magnetic switches not switching as desired.....	44
7	Maintenance	45
7.1	Notes	45
7.2	Maintenance intervals.....	46
7.3	Lubricants/greasing areas (basic lubrication).....	47
7.4	Disassembly and assembly	48
7.4.1	Variant with dust cover	48
7.4.2	Version without gripping force maintenance.....	48
7.4.3	Version with gripping force maintenance O.D.	49
7.4.4	Version with gripping force maintenance I.D.	52
7.4.5	Version with force amplification cylinder (KVZ)	54
7.4.6	Notes for assembly	56
7.4.7	Screw tightening torques.....	57
7.4.8	Spring force information for assembly	57
7.5	Drawings.....	57
7.5.1	Basic module	58
7.5.2	Variant with dust cover	59
7.5.3	Variant with force amplification cylinder	60
8	Translation of original declaration of incorporation	61

9 Annex to Declaration of Incorporation..... 62

1 General

1.1 About this manual

This manual contains important information for a safe and appropriate use of the product.

This manual is an integral part of the product and must be kept accessible for the personnel at all times.

Before starting work, the personnel must have read and understood this operating manual. Prerequisite for safe working is the observance of all safety instructions in this manual.

Illustrations in this manual are provided for basic understanding and may differ from the actual product design.

In addition to these instructions, the documents listed under [Applicable documents](#) [► 7] are applicable.

1.1.1 Presentation of Warning Labels

To make risks clear, the following signal words and symbols are used for safety notes.



⚠ DANGER

Danger for persons!

Non-observance will inevitably cause irreversible injury or death.



⚠ WARNING

Dangers for persons!

Non-observance can lead to irreversible injury and even death.



⚠ CAUTION

Dangers for persons!

Non-observance can cause minor injuries.

NOTICE

Material damage!

Information about avoiding material damage.

1.1.2 Definition of Terms

The term "product" replaces the product name on the title page in this manual.

1.1.3 Applicable documents

- General terms of business*
- Catalog data sheet of the purchased product *
- Assembly and operating manuals of the accessories *
- For ATEX versions: Supplementary sheet "Installation and operating instructions - EX" *

The documents marked with an asterisk (*) can be downloaded on our homepage **schunk.com**

1.1.4 Sizes

This operating manual applies to the following sizes:

- PZN-plus 40
- PZN-plus 50
- PZN-plus 64
- PZN-plus 80
- PZN-plus 100
- PZN-plus 125
- PZN-plus 160
- PZN-plus 200
- PZN-plus 240
- PZN-plus 300
- PZN-plus 380

1.1.5 Variants

This operating manual applies to the following variations:

- PZN-plus
- PZN-plus with gripping force maintenance O.D. gripping
- PZN-plus with gripping force maintenance I.D. gripping
- PZN-plus Force intensified version (KVZ)
- PZN-plus Dust-tight
- PZN-plus ATEX-Version (EX)
- PZN-plus Anti-corrosion version
- PZN-plus Precision version

1.2 Warranty

If the product is used as intended, the warranty is valid for 36 months from the ex-works delivery date under the following conditions:

- Observe the specified maintenance and lubrication intervals
- Observe the ambient conditions and operating conditions

Parts touching the workpiece and wear parts are not included in the warranty.

1.3 Scope of delivery

The scope of delivery includes

- 3-Finger Centric Gripper PZN-plus in the version ordered
- Assembly and Operating Manual
- Accessory pack

1.3.1 Accessories kit

Content of the accessory pack:

- 6 x Centering sleeves for mounting
- 2 x O-ring for hose-free direct connection
- 2 x screw plug for hose connection
- 2 x Cylindrical pin

ID.-No. of the accessory pack

Accessory pack for	PZN-plus	PZN-plus-High-temperature (HT)
PZN-plus 40	5521694	5521695
PZN-plus 50	5520796	5520797
PZN-plus 64	5512728	395512728
PZN-plus 80	5512729	395512729
PZN-plus 100	5512730	395512730
PZN-plus 125	5512731	395512731
PZN-plus 160	5512732	395512732
PZN-plus 200	5512733	395512733
PZN-plus 240	5514005	395514005
PZN-plus 300	5514240	395514240
PZN-plus 380	5520730	1343258

1.4 Accessories

A wide range of accessories are available for this product
For information regarding which accessory articles can be used
with the corresponding product variants, see catalog data sheet.

1.4.1 Sealing kit

Seal kit for	PZN-plus	PZN-plus- High- temperature (HT)	PZN-plus- Dust-tight	PZN-plus- Force intensified version (KVZ)
PZN-plus 40	5516815	395516815	5518720	-
PZN-plus 50	5516816	395516816	5518721	-
PZN-plus 64	0303450	39303450	5518722	5515869
PZN-plus 80	0303451	39303451	5518723	5515870
PZN-plus 100	0303452	39303452	5518724	5515871
PZN-plus 125	0303453	39303453	5518725	5515872
PZN-plus 160	0303454	39303454	5518726	5515873
PZN-plus 200	0303455	39303455	5518727	-
PZN-plus 240	0303456	39303456	5518728	-
PZN-plus 300	0303457	39303457	5518729	-
PZN-plus 380	0303458	39303458	5522513	-

Contents of the sealing kit, [Drawings](#) [▶ 57].

2 Basic safety notes

2.1 Intended use

The product is designed exclusively for gripping and temporarily holding workpieces or objects.

- The product may only be used within the scope of its technical data, [Technical data](#) [► 18].
- When implementing and operating components in safety-related parts of the control systems, the basic safety principles in accordance with DIN EN ISO 13849-2 apply. The proven safety principles in accordance with DIN EN ISO 13849-2 also apply to categories 1, 2, 3 and 4.
- The product is intended for installation in a machine/system. The applicable guidelines must be observed and complied with.
- The product is intended for industrial and industry-oriented use.
- Appropriate use of the product includes compliance with all instructions in this manual.

2.2 Not intended use

It is not intended use if the product is used, for example, as a pressing tool, stamping tool, lifting gear, guide for tools, cutting tool, clamping device or a drilling tool.

- Any utilization that exceeds or differs from the appropriate use is regarded as misuse.

2.3 Constructional changes

Implementation of structural changes

By conversions, changes, and reworking, e.g. additional threads, holes, or safety devices can impair the functioning or safety of the product or damage it.

- Structural changes should only be made with the written approval of SCHUNK.

2.4 Spare parts

Use of unauthorized spare parts

Using unauthorized spare parts can endanger personnel and damage the product or cause it to malfunction.

- Use only original spare parts or spares authorized by SCHUNK.

2.5 Gripper fingers

Requirements for the gripper fingers

Stored energy within the product creates the risk of serious injuries and significant property damage.

- Arrange the gripper fingers in a way that the product reaches either the position "open" or "closed" in a de-energized state.
- Only exchange the gripper fingers when no residual energy remains in the product.
- Make sure that the product and the top jaws are a sufficient size for the application.

2.6 Environmental and operating conditions

Required ambient conditions and operating conditions

Incorrect ambient and operating conditions can make the product unsafe, leading to the risk of serious injuries, considerable material damage and/or a significant reduction to the product's life span.

See also [Technical data](#) [► 18].

2.7 Personnel qualification

Inadequate qualifications of the personnel

If the personnel working with the product is not sufficiently qualified, the result may be serious injuries and significant property damage.

- All work may only be performed by qualified personnel.
- Before working with the product, the personnel must have read and understood the complete assembly and operating manual.
- Observe the national safety regulations and rules and general safety instructions.

The following personal qualifications are necessary for the various activities related to the product:

Trained electrician	Due to their technical training, knowledge and experience, trained electricians are able to work on electrical systems, recognize and avoid possible dangers and know the relevant standards and regulations.
Qualified personnel	Due to its technical training, knowledge and experience, qualified personnel is able to perform the delegated tasks, recognize and avoid possible dangers and knows the relevant standards and regulations.
Instructed person	Instructed persons were instructed by the operator about the delegated tasks and possible dangers due to improper behaviour.
Service personnel of the manufacturer	Due to its technical training, knowledge and experience, service personnel of the manufacturer is able to perform the delegated tasks and to recognize and avoid possible dangers.

2.8 Personal protective equipment

Use of personal protective equipment

Personal protective equipment serves to protect staff against danger which may interfere with their health or safety at work.

- When working on and with the product, observe the occupational health and safety regulations and wear the required personal protective equipment.
- Observe the valid safety and accident prevention regulations.
- Wear protective gloves to guard against sharp edges and corners or rough surfaces.
- Wear heat-resistant protective gloves when handling hot surfaces.
- Wear protective gloves and safety goggles when handling hazardous substances.
- Wear close-fitting protective clothing and also wear long hair in a hairnet when dealing with moving components.

2.9 Notes on safe operation

Incorrect handling of the personnel

Incorrect handling and assembly may impair the product's safety and cause serious injuries and considerable material damage.

- Avoid any manner of working that may interfere with the function and operational safety of the product.
- Use the product as intended.
- Observe the safety notes and assembly instructions.
- Do not expose the product to any corrosive media. This does not apply to products that are designed for special environments.
- Eliminate any malfunction immediately.
- Observe the care and maintenance instructions.
- Observe the current safety, accident prevention and environmental protection regulations regarding the product's application field.

2.10 Transport

Handling during transport

Incorrect handling during transport may impair the product's safety and cause serious injuries and considerable material damage.

- When handling heavy weights, use lifting equipment to lift the product and transport it by appropriate means.
- Secure the product against falling during transportation and handling.
- Stand clear of suspended loads.

2.11 Malfunctions

Behavior in case of malfunctions

- Immediately remove the product from operation and report the malfunction to the responsible departments/persons.
- Order appropriately trained personnel to rectify the malfunction.
- Do not recommission the product until the malfunction has been rectified.
- Test the product after a malfunction to establish whether it still functions properly and no increased risks have arisen.

2.12 Disposal

Handling of disposal

The incorrect handling of disposal may impair the product's safety and cause serious injuries as well as considerable material and environmental harm.

- Follow local regulations on dispatching product components for recycling or proper disposal.

2.13 Fundamental dangers

General

- Observe safety distances.
- Never deactivate safety devices.
- Before commissioning the product, take appropriate protective measures to secure the danger zone.
- Disconnect power sources before installation, modification, maintenance, or calibration. Ensure that no residual energy remains in the system.
- If the energy supply is connected, do not move any parts by hand.
- Do not reach into the open mechanism or movement area of the product during operation.

2.13.1 Protection during handling and assembly

Incorrect handling and assembly

Incorrect handling and assembly may impair the product's safety and cause serious injuries and considerable material damage.

- Have all work carried out by appropriately qualified personnel.
- For all work, secure the product against accidental operation.
- Observe the relevant accident prevention rules.
- Use suitable assembly and transport equipment and take precautions to prevent jamming and crushing.

Incorrect lifting of loads

Falling loads may cause serious injuries and even death.

- Stand clear of suspended loads and do not step into their swiveling range.
- Never move loads without supervision.
- Do not leave suspended loads unattended.

2.13.2 Protection during commissioning and operation

Falling or violently ejected components

Falling and violently ejected components can cause serious injuries and even death.

- Take appropriate protective measures to secure the danger zone.
- Never step into the danger zone during operation.

2.13.3 Protection against dangerous movements

Unexpected movements

Residual energy in the system may cause serious injuries while working with the product.

- Switch off the energy supply, ensure that no residual energy remains and secure against inadvertent reactivation.
- Never rely solely on the response of the monitoring function to avert danger. Until the installed monitors become effective, it must be assumed that the drive movement is faulty, with its action being dependent on the control unit and the current operating condition of the drive. Perform maintenance work, modifications, and attachments outside the danger zone defined by the movement range.
- To avoid accidents and/or material damage, human access to the movement range of the machine must be restricted. Limit/prevent accidental access for people in this area due through technical safety measures. The protective cover and protective fence must be rigid enough to withstand the maximum possible movement energy. EMERGENCY STOP switches must be easily and quickly accessible. Before starting up the machine or automated system, check that the EMERGENCY STOP system is working. Prevent operation of the machine if this protective equipment does not function correctly.

2.13.4 Protection against electric shock

Possible electrostatic energy

Components or assembly groups may become electrostatically charged. When the electrostatic charge is touched, the discharge may trigger a shock reaction leading to injuries.

- The operator must ensure that all components and assembly groups are included in the local potential equalisation in accordance with the applicable regulations.
- While paying attention to the actual conditions of the working environment, the potential equalisation must be implemented by a specialist electrician according to the applicable regulations.
- The effectiveness of the potential equalisation must be verified by executing regular safety measurements.

2.14 Notes on particular risks



⚠ DANGER

Risk of fatal injury from suspended loads!

Falling loads can cause serious injuries and even death.

- Stand clear of suspended loads and do not step within their swiveling range.
- Never move loads without supervision.
- Do not leave suspended loads unattended.
- Wear suitable protective equipment.



⚠ WARNING

Risk of injury from objects falling and being ejected!

Falling and ejected objects during operation can lead to serious injury or death.

- Take appropriate protective measures to secure the danger zone.



⚠ WARNING

Risk of injury due to unexpected movements!

If the power supply is switched on or residual energy remains in the system, components can move unexpectedly and cause serious injuries.

- Before starting any work on the product: Switch off the power supply and secure against restarting.
- Make sure, that no residual energy remains in the system.



⚠ WARNING

Risk of injury from crushing and impacts!

Serious injury could occur during the base jaw procedure and when breaking or loosening the gripper fingers.

- Wear suitable protective equipment.
- Do not reach into the open mechanism or the movement area of the product.



⚠ WARNING

Risk of injury from sharp edges and corners!

Sharp edges and corners can cause cuts.

- Use suitable protective equipment.

**⚠ WARNING****Risk of injury due to spring forces!**

Parts are under spring tension on products which clamp using spring force or which have gripping force maintenance. While disassembling components can move unexpectedly and cause serious injuries.

- Disassemble the product cautiously.
- Make sure that no residual energy remains in the system.

**⚠ WARNING****Risk of injury from objects falling during energy supply failure**

Products with a mechanical gripping force maintenance can, during energy supply failure, still move independently in the direction specified by the mechanical gripping force maintenance.

- Secure the end positions of the product with SCHUNK SDV-P pressure maintenance valves.

3 Technical data

Designation	PZN-plus
Pressure medium	Compressed air, compressed air quality according to ISO 8573-1: 7:4:4
Nominal operating pressure [bar]	6
Minimum pressure [bar] without maintenance of gripping force with maintenance of gripping force	2.5 4
Max. pressure [bar] without gripping force maintenance with gripping force maintenance Force intensified version (KVZ)	8 6.5 6
Pressure range for air purge [bar]	0.5 - 1

More technical data is included in the catalog data sheet. Whichever is the latest version.

Ambient conditions and operating conditions

Designation	PZN-plus
Ambient temperature [°C] min. max.	+5 +90 / (V/HT: +130)
IP protection class *	40 / (SD: 64)
Noise emission [dB(A)]	≤ 70

* For use in dirty ambient conditions (e.g. sprayed water, vapors, abrasion or processing dust) SCHUNK offers corresponding product options as standard. SCHUNK also offers customized solutions for special applications in dirty ambient conditions.

4 Design and description

4.1 Design

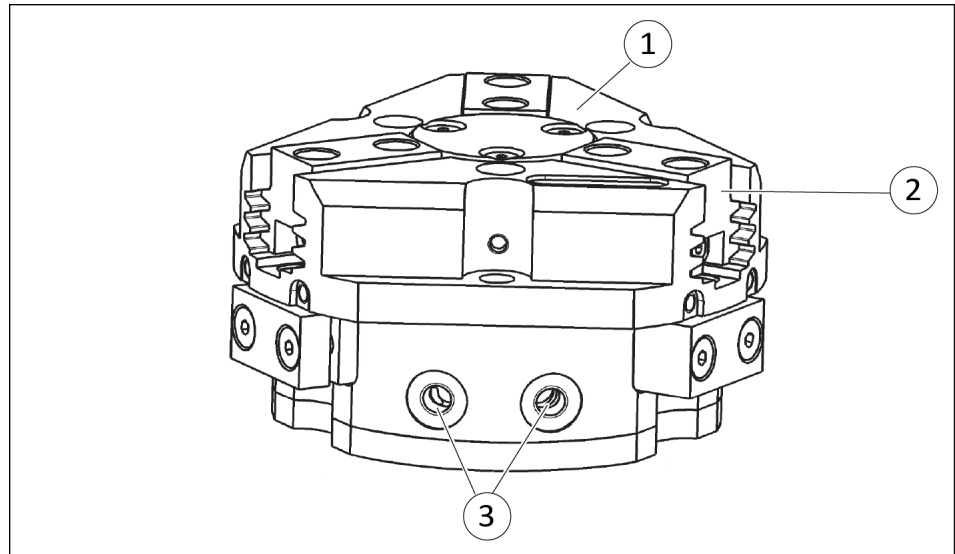

3-Finger Centric Gripper

1	Housing
2	Base jaw
3	Compressed air main connection

4.2 Description

Universal 3-finger centric gripper with high gripping force and high maximum moments due to multi-tooth guidance.

5 Assembly

5.1 Installing and connecting



⚠ DANGER

Danger of explosion in potentially explosive areas!

- Observe supplementary sheet for products with explosion-resistant versions "PZN-plus -...-EX".



⚠ WARNING

Risk of injury due to unexpected movements!

If the power supply is switched on or residual energy remains in the system, components can move unexpectedly and cause serious injuries.

- Before starting any work on the product: Switch off the power supply and secure against restarting.
- Make sure, that no residual energy remains in the system.

NOTICE

Damage to the gripper is possible!

If the maximum permissible finger weight or the permissible mass moment of inertia of the fingers is exceeded, the gripper can be damaged.

- A jaw movement always has to be without jerks and bounce.
 - You must therefore implement sufficient reduction and/or damping.
 - Observe the diagrams and information in the catalog data sheet.
-
- Check the evenness of the mounting surface, [Mechanical connection](#) [▶ 21].
 - Only open the required air connections (main connection or direct connection), [Pneumatic connection](#) [▶ 25].
 - Connect the product via the hose-free direct connection.
 - ✓ Use O-rings from the accessory pack.
 - ✓ Seal main air connections which are not required with locking screws.
 - OR: Connect compressed air lines to the main air connections "A" and "B".
 - ✓ Screw in air connections (plug connections).
OR: Screw on throttle valve in order to be able to perform sufficient throttling and/or dampening.

- Screw the product to the machine/system, [Mechanical connection](#) [▶ 21].
 - ✓ When mounting from the rear: use cylindrical pins for fixing the product in place.
 - ✓ If necessary, use appropriate connection elements (adapter plates).
 - ✓ Observe requirements for the adapter plate, [Mechanical connection](#) [▶ 22].
 - ✓ Observe the maximal tightening torque, admissible screw-in depth and, if necessary, strength class.
- Secure the gripper fingers to the base jaws, [Mechanical connection](#) [▶ 21].
 - ✓ Use centering sleeves from the enclosed accessory pack.
- If necessary, fit a pressure piece for spring-supported positioning of the workpiece against a stop, [Mounting of the gripper by using a spring loaded pressure-piece](#) [▶ 24].
- Connect the sensor, see assembly and operating manual of the sensor.
- Mount the sensor, [Mounting the sensor](#) [▶ 26].

5.2 Connections

5.2.1 Mechanical connection

Evenness of the mounting surface

The values apply to the whole mounting surface to which the product is mounted.

Requirements for evenness of the mounting surface (Dimensions in mm)

Edge length	Permissible unevenness
< 100	< 0.02
> 100	< 0.05

Requirements for customer adapter plates

If the adapter plate has bores or recesses and therefore the product is not fully flush, the minimum support surface must be adhered to. The recess/bore in the adapter plate may not exceed the dimension "A"; for dimensions, see the following table.

The product can be assembled from two sides.

Connections at the housing and on the base jaws

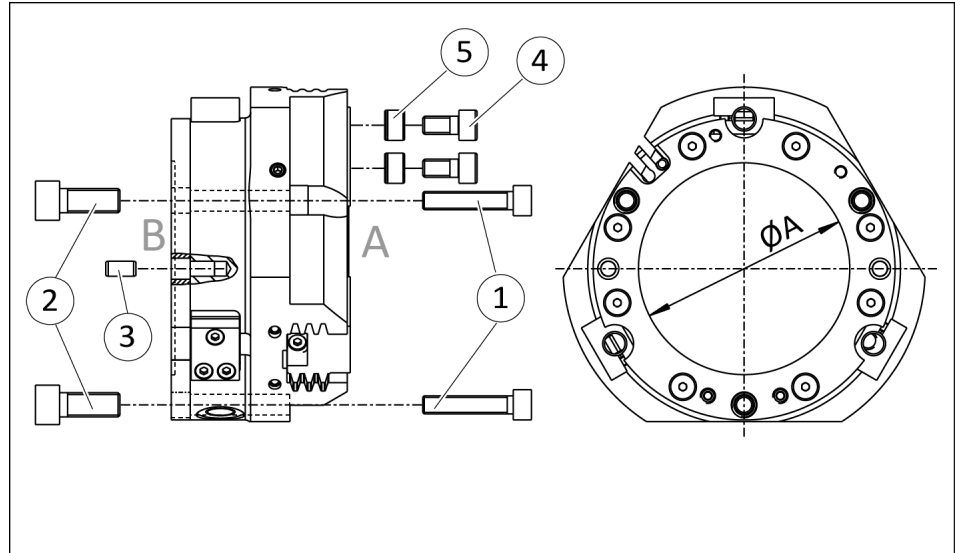

Assembly options

Item		40	50	64	80	100	125
Mounting the product from the front (side A)							
1	Mounting screw (3 x)	M3	M3	M5	M6	M6	M8
Mounting the product from the rear (side B)							
2	Mounting screw (3 x)	-	M4	M6	M8	M8	M10
	Max. depth of engagement from locating surface [mm] • without gripping force maintenance	-	10	13	17	18	21
	Max. depth of engagement from locating surface [mm] • with gripping force maintenance (AS / IS)	-	20.5	26	32	38	45.5
3	Fitting bore for cylindrical pins *	Ø2H7	Ø3H7	Ø4H7	Ø5H7	Ø5H7	Ø6H7
Possible recess in the adapter plate							
A	Max. recess [mm]	Ø24	Ø32	Ø40	Ø55	Ø70	Ø85
Affixing the gripper fingers							
4	Mounting screw(2x)	M2.5	M3	M4	M5	M6	M6
	Max. depth of engagement from locating surface [mm]	6	8	10	10	13	13
5	Centering sleeve * [mm]	Ø4	Ø5	Ø6	Ø8	Ø10	Ø10

*) Contained in accessory pack.

Item		160	200	240	300	380
Mounting the product from the front (side A)						
1	Mounting screw (3 x)	M8	M10	M12	M16	M20
Mounting the product from the rear (side B)						
2	Mounting screw (3 x)	M10	M12	-	-	-
	Max. depth of engagement from locating surface [mm] without gripping force maintenance	21.5	25	-	-	-
	Max. depth of engagement from locating surface [mm] with gripping force maintenance (AS / IS)	51.5	61	-	-	-
3	Fitting bore for cylindrical pins *	Ø6H7	Ø8H7	Ø8H7	Ø10H7	Ø12H7
Possible recess in the adapter plate						
A	Max. recess [mm]	Ø115	Ø150	Ø196	Ø236	Ø292
Affixing the gripper fingers						
4	Mounting screw(2x)	M10	M12	M12	M16	M20
	Max. depth of engagement from locating surface [mm]	17	17	20	26	30
5	Centering sleeve * [mm]	Ø14	Ø16	Ø16	Ø22	Ø28

*) Contained in accessory pack.

5.2.1.1 Mounting of the gripper by using a spring loaded pressure-piece



⚠ CAUTION

The spring-loaded pressure piece is under spring tension.

The pressure piece can fly out in an uncontrolled fashion and cause contusions.

- During assembly or disassembly, be especially careful with the springs.
-

When mounting the gripper from the side of the gripper fingers, the assembly of the pressure piece must be done **after** the mounting of the gripper.

Mounting the pressure piece is described in the insert "Installation instructions - pressure piece", which is included in the pressure piece's scope of delivery.

5.2.2 Pneumatic connection

NOTE

- Observe the requirements for the compressed air supply, [Technical data](#) [▶ 18].
- In case of compressed air loss (cutting off the energy line), the components lose their dynamic effects and do not remain in a secure position. However, the use of a SDV-P pressure maintenance valve is recommended in this case in order to maintain the dynamic effect for some time. Product variants are also offered with mechanical gripping force via springs, which also ensure a minimum clamping force in the event of a pressure drop.

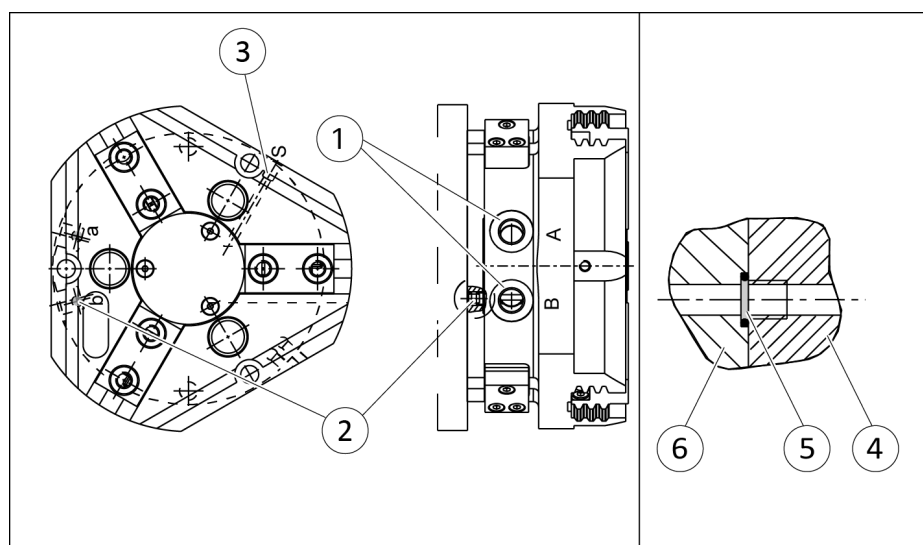

Air connections

1	Main connections (Hose connection) (A = open, B = close)				
2	Hose-free direct connection (a = open, b = close)				
3	Air purge connection				
Hose-free direct connection					
4	Product	5	O-ring	6	Attachment

Thread diameter of the air connections

Item	Mounting	40	50	64	80	100/ 125	160	200	240	300/ 380
1	Main connections (Hose connection)	M3	M5	M5	M5	G1/8"			G1/4"	
2	Hose-free direct connection	M3	M3	M4	M4	M5	M4	M5	M5	M8
3	Air purge connection	M3	M5							

5.3 Mounting the sensor

NOTE

Observe the assembly and operating manual of the sensor for mounting and connecting.

The product is prepared for the use of sensors.

- For the exact type designations of suitable sensors, please see catalog datasheet and [Overview of sensors](#) [▶ 26].
- For technical data for the suitable sensors, see assembly and operating manual and catalog datasheet.
 - The assembly and operating manual and catalog datasheet are included in the scope of delivery for the sensors and are available at schunk.com.
- Information on handling sensors is available at schunk.com or from SCHUNK contact persons.

5.3.1 Overview of sensors

Designation	PZN-plus										
	40	50	64	80	100	125	160	200	240	300	380
Magnetic switch MMS 22	X	X	X	X	X	X	X	X	X	X	X
Programmable magnetic switch MMS 22-PI1	X	X	X	X	X	X	X	X	X	X	X
Programmable magnetic switch MMS 22-PI2	X	X	X	X	X	X	X				
Programmable magnetic switch MMS-P 22	X	X	X	X	X	X	X				
Inductive proximity switch IN 80			X	X	X	X	X	X	X	X	X
Reed switch RMS 80			X	X	X	X	X	X	X	X	X
Flexible position sensor FPS-F5 with FPS-S M8			X	X	X	X	X	X	X	X	
Analog position sensor APS-M1			X	X	X	X	X	X	X	X	X
Analog position sensor APS-Z80			X	X	X	X	X	X	X	X	X
Radio system RSS R1/T2 with Reed switch RMS 80			X	X	X	X	X	X	X	X	X
Force-measuring jaw FMS		X	X	X	X	X	X	X		X	

5.3.2 Setting dimensions for magnetic switches

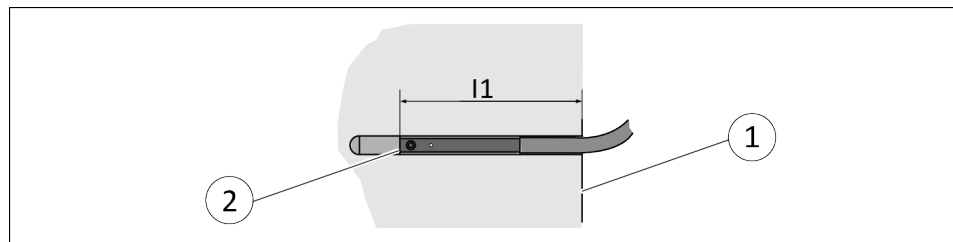

* Setting dimension l_1 , from product bottom edge (1) to front sensor (2)

The setting dimension applies for the following sensors:

- Programmable magnetic switch MMS 22-PI1
- Programmable magnetic switch MMS 22-PI2
- Programmable magnetic switch MMS-P 22

Size	l_1^* [mm]	Size	l_1^* [mm]
40	20.3	80-KVZ	51.9
40 AS	28.2	80 AS-KVZ	66.9
40 IS	28.3	80 IS-KVZ	66.9
40-KVZ	34.8	100	29.8
40 AS-KVZ	42.8	100 AS	49.9
40 IS-KVZ	42.8	100 IS	49.8
50	21.7	100-KVZ	59.8
50 AS	32.2	100 AS-KVZ	79.8
50 IS	32.1	100 IS-KVZ	79.8
50-KVZ	39.7	125	32.5
50 AS-KVZ	50.1	125 AS	56.8
50 IS-KVZ	50.1	125 IS	57.0
64	24.5	125-KVZ	67.5
64 AS	38.0	125 AS-KVZ	92.0
64 IS	38.0	125 IS-KVZ	92.0
64-KVZ	45.5	160	35.9
64 AS-KVZ	59.0	160 AS	66.2
64 IS-KVZ	59.0	160 IS	65.9
80	26.9	160-KVZ	75.9
80 AS	42.5	160 AS-KVZ	105.9
80 IS	41.9	160 IS-KVZ	105.9

NOTE

The magnetic switch MMS 22-PI1 can be adjusted and taught in two ways.

- "Standard mode" allows for quick installation on the T-nut preset by SCHUNK in the groove or the defined setting dimension "l1."
 - In "Optimal Mode", the sensor identifies the optimal position in the groove itself.
SCHUNK recommends "Optimal Mode" for setting the sensors.
-

Further information on the installation of the sensor, [Mounting MMS 22-PI1 programmable magnetic switch](#) [► 31]

5.3.3 Switch-off hysteresis for magnetic switches

Sensors MMS 22, MMS-P 22, MMS 22-PI1 and MMS 22-PI2

The smallest detectable difference in stroke is defined in the following table:

The smallest detectable difference in stroke based on the nominal stroke

For grippers with X mm nominal stroke per jaw	Min. query range per jaw/ min. queried stroke difference per jaw
$X \leq 5 \text{ mm}$	30% of the nominal stroke per jaw
$X > 5 \text{ mm to } X \leq 10 \text{ mm}$	20% of the nominal stroke per jaw
$X > 10 \text{ mm}$	10% of the nominal stroke per jaw

Example: Product with 7 mm nominal stroke per jaw

$$7 \text{ mm} * 20\% = 1.4 \text{ mm}$$

5.3.4 Turn control cam

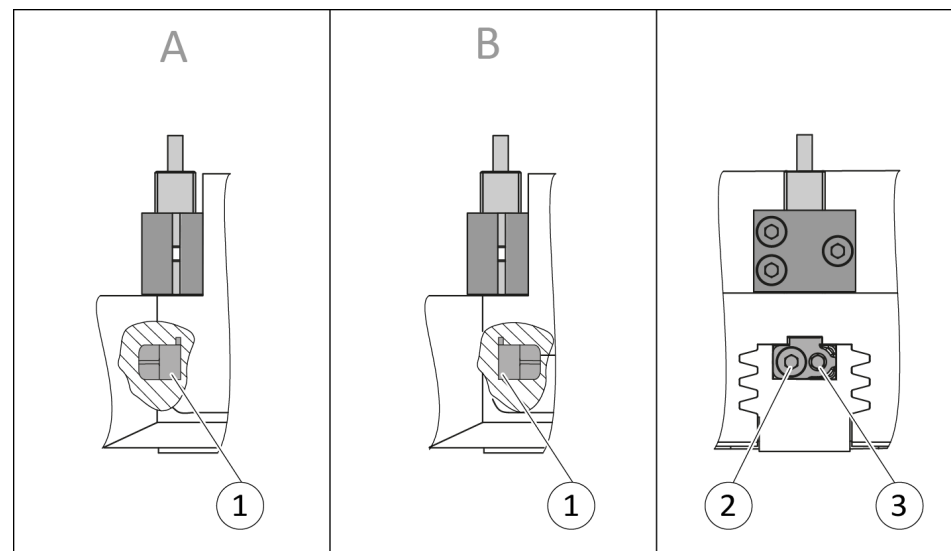

Turn control cam, example control cam for inductive monitoring

Depending on the jaw stroke, it may be necessary to change the alignment of the control cam for the sensors IN 80 and RMS 80.

In the image, the installation situation (A) shows the control cam in the delivery state of the product and the installation situation (B) shows the turned control cam.

In order to change the alignment of the control cam, proceed as follows:

- Undo the screw (2).
- Remove control cam (1) from the product, turn and re-insert it into the product.
- Turn the screw (3) to push the position of the control cam (1).

5.3.5 Mounting MMS 22 magnetic switch

NOTICE

Risk of damage to the sensor during assembly!

- Observe the maximal tightening torque.

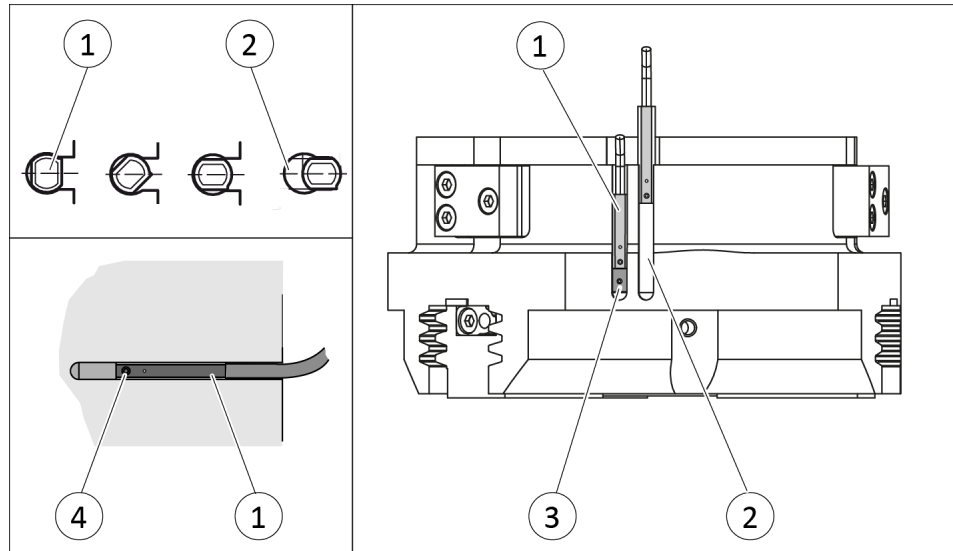

Positioning the magnetic switches

Position "Gripper open" or "Part gripped (I.D. gripping)"

- Bring product in the position to be set.
- If necessary remove T-nut (3).
- Turn the sensor 1 (1) into the groove (2).
OR: Slide the sensor 1 (1) into the groove (2) until the sensor 1 (1) stops at the end of the groove.
- Pull the sensor 1 (1) back again slowly until it switches.
- Secure the sensor 1 (1) using the set-screw (4).
Tightening torque: 10 Ncm
- Bring product into the "Gripper open" or "Part gripped" position and test the function.

Position "Gripper closed" or "Part gripped (O.D. gripping)"

- Bring product in the position in which it is to be set.
- If necessary remove T-nut (3).
- Turn the sensor 2 (1) into the groove (2).
OR: Slide sensor 2 (1) into the groove (2) in the direction of the housing middle (3), until the sensor 2 (1) switches.
- Secure the sensor 2 (1) using the set-screw (4).
Tightening torque: 10 Ncm
- Bring product into the "Gripper closed" or "Part gripped" position and test the function.

5.3.6 Mounting MMS 22-PI1 programmable magnetic switch

NOTICE

Risk of damage to the sensor during assembly!

- Observe the maximal tightening torque.

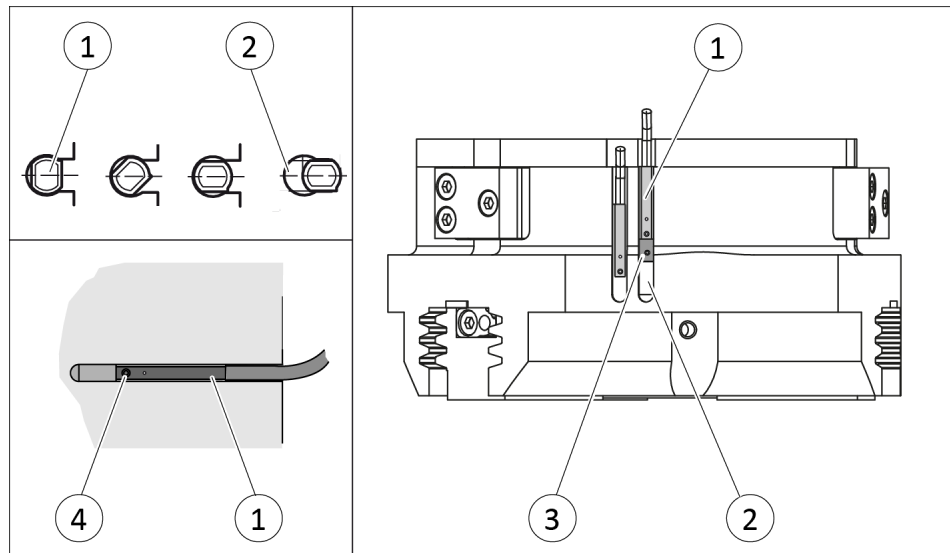

NOTE

The magnetic switch MMS 22-PI1 can be adjusted and taught in two ways.

- "Standard mode" allows for quick installation on the T-nut preset by SCHUNK in the groove or the defined setting dimension "I1."
- In "Optimal Mode", the sensor identifies the optimal position in the groove itself.
SCHUNK recommends "Optimal Mode" for setting the sensors.

Setting the sensor in "Optimum mode"

- Bring gripper in the position in which it is to be set.
- Hold teaching tool to the sensor 1 (1) until the sensor flashes.
- Slide sensor 1 (1) into the groove (2), until the sensor 1 flashes rapidly.
 - ✓ The optimal position is displayed.
- Secure the sensor 1 (1) using the set-screw (4).
Tightening torque: 10 Ncm
- Hold teaching tool to the sensor 1 (1), to confirm the position.
 - ✓ The sensor 1 (1) has been taught in.
- Repeat steps for sensor 2.

Alternatively for size 40 – 160:

Setting the sensor in "Standard mode"

- Turn the sensor 1 (1) into the groove (2).
OR: Slide the sensor 1 (1) into the groove (2) until the sensor 1 (1) stops at the T-nut (3).
- Secure the sensor 1 (1) using the set-screw (4).
Tightening torque: 10 Ncm
- Adjust sensor 1 (1), see sensor assembly and operating manual.
- Repeat steps for sensor 2.

NOTE

If there is no T-nut available, slide the sensor according to dimension l1 into the groove (2), [Setting dimensions for magnetic switches](#) [▶ 27].

5.3.7 Mounting programmable MMS 22-PI2 magnetic switch

NOTICE

Risk of damage to the sensor during assembly!

- Observe the maximal tightening torque.

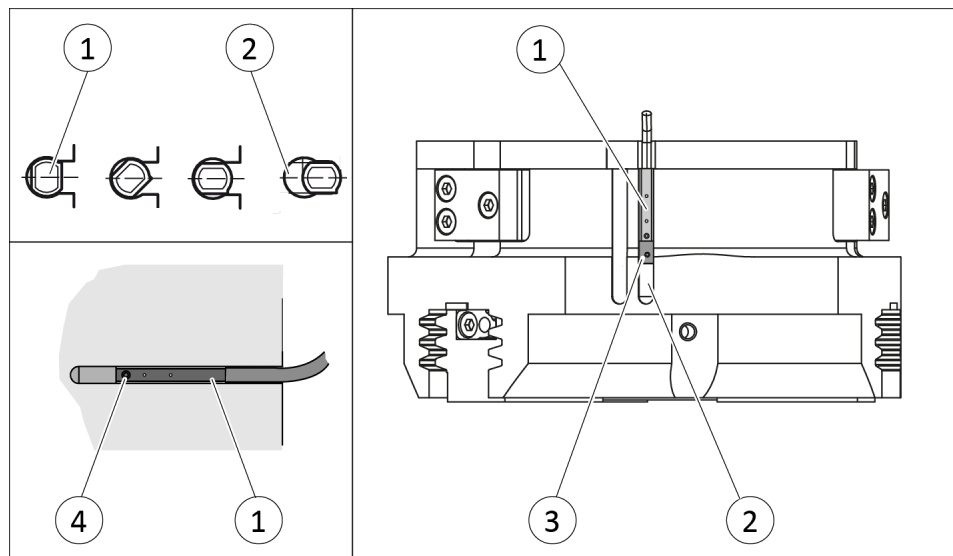

NOTE

If there is no T-nut available, slide the sensor according to dimension l1 into the groove (2), [Setting dimensions for magnetic switches](#) [▶ 27].

- Turn the sensor (1) into the groove (2).
OR: Slide the sensor (1) into the groove (2) until the sensor (1) stops at the T-nut (3).
- Secure the sensor (1) using the set-screw (4).
Tightening torque: 10 Ncm

- Adjust sensor (1), see sensor assembly and operating manual.

5.3.8 Mounting programmable MMS-P 22 magnetic switch

NOTICE

Risk of damage to the sensor during assembly!

- Observe the maximal tightening torque.

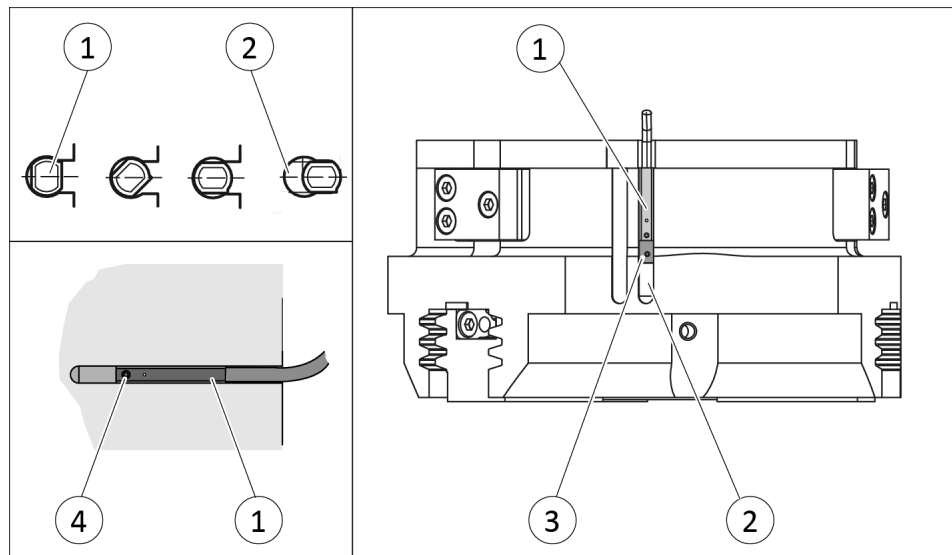

NOTE

If there is no T-nut available, slide the sensor according to dimension I1 into the groove (2), [Setting dimensions for magnetic switches](#) [▶ 27].

- Turn the sensor (1) into the groove (2).
OR: Slide the sensor (1) into the groove (2) until the sensor (1) stops at the T-nut (3).
- Secure the sensor (1) using the set-screw (4).
Tightening torque: 10 Ncm
- Adjust sensor (1), see sensor assembly and operating manual.

5.3.9 Mounting inductive proximity switch IN 80

NOTICE

Blockade of the gripper after setting or replacing of the switching cam!

The switching cam can be tilt in the guide, if it was not fixed exactly in the base jaw.

- Apply the switching cam in the direction of the base jaw, so that the cam does not contact the housing of the gripper.

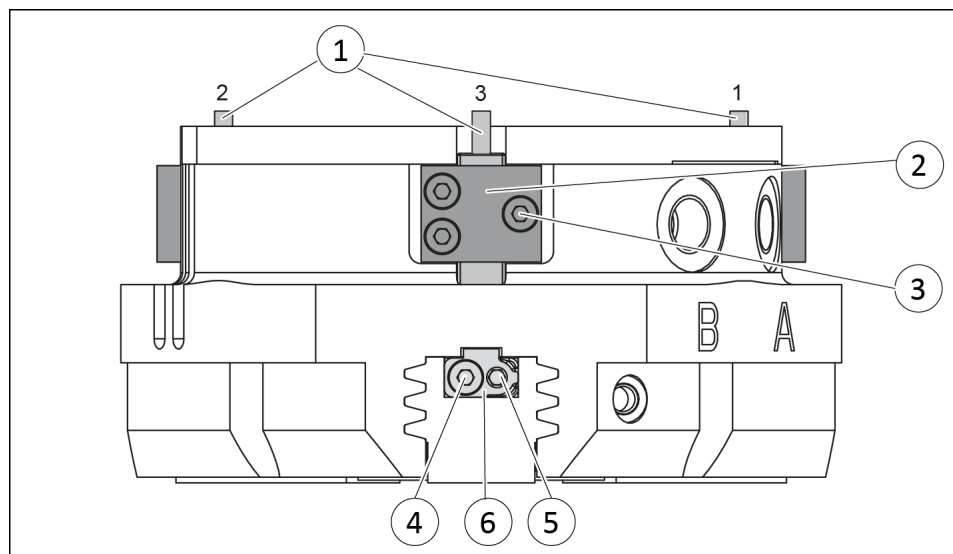

NOTE

The screws (4) and (5) differ in length. With size PZN-plus 380, these screws on sensor 3 (1) are the same length.

Variant Dust-tight:

Before attaching the sensor, remove the sealing bolts from the bracket. Before adjusting the control cam, unscrew the set-screw from the side cover.

Position "Gripper open" or "Part gripped (I.D. gripping)"

- Slide the sensor 1 (1) or sensor 2 (1) to the stop into the bracket (2).
- Tighten the screw (3) on the bracket (2).
Tightening torque: 0.2 Nm
- Open gripper or grip part.
- Undo the screw (4).
- Turn the screw (5) to push the position of the control cam (6).
 - ✓ Slide control cam (6) inwards until the sensor 1 (1) no longer responds.
Move the control cam (6) back towards the outside until the sensor 1 (1) begins to switch.

-
- Tighten screw (4) and in doing so press the control cam in the direction of the gripper fingers. **NOTICE! The control cam may tilt in the guide if it has not been tightened properly.**
 - ✓ Switching point is set.
 - Bring product into the "Gripper open" or "Part gripped" position and test the function.
-

NOTE

If the switching position cannot be queried, it may be that the alignment of the control cam has to be changed, [Turn control cam](#) [▶ 29].

Position "Gripper closed" or "Part gripped (O.D. gripping)"

- Slide the sensor 3 (1) to the stop into the bracket (2).
 - Tighten the screw (3) on the bracket (2).
Tightening torque: 0.2 Nm
 - Close gripper or grip part.
 - Undo the screw (4).
 - Turn the screw (5) to push the position of the control cam (6).
 - ✓ Slide control cam (6) outwards until the sensor 3 (1) no longer responds.
Move the control cam (6) back towards the inside until the sensor 3 (1) begins to switch.
 - Tighten screw (4) and in doing so press the control cam in the direction of the gripper fingers. **NOTICE! The control cam may tilt in the guide if it has not been tightened properly.**
 - ✓ Switching point is set.
 - Bring product into the "Gripper closed" or "Part gripped" position and test the function.
-

NOTE

If the switching position cannot be queried, it may be that the alignment of the control cam has to be changed, [Turn control cam](#) [▶ 29].

Variant Dust-tight:

Screw in set-screw into the side cover.

5.3.10 Mounting the reed switch RMS 80

NOTICE

Blockade of the gripper after setting or replacing of the switching cam!

The switching cam can be tilt in the guide, if it was not fixed exactly in the base jaw.

- Apply the switching cam in the direction of the base jaw, so that the cam does not contact the housing of the gripper.

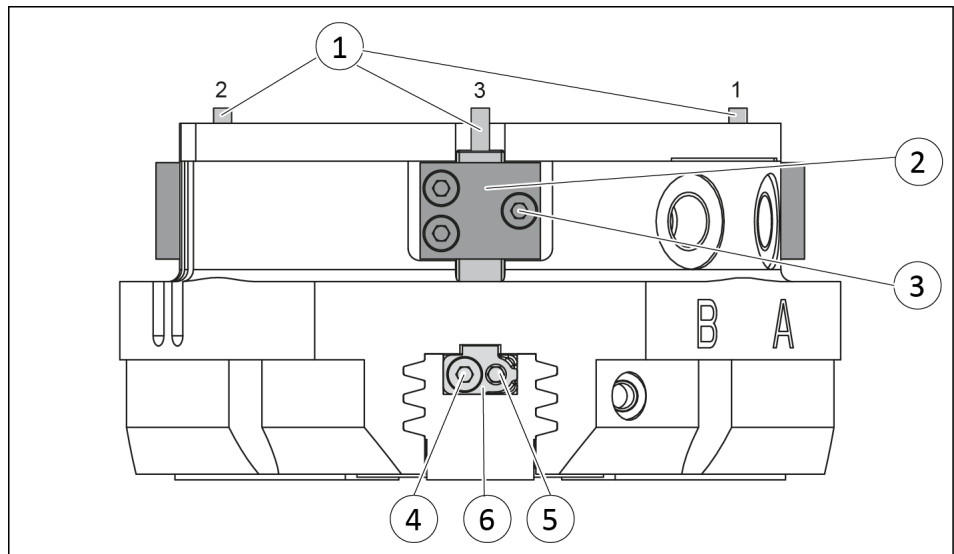

NOTE

The screws (4) and (5) differ in length. With size PZN-plus 380, these screws on sensor 3 (1) are the same length.

Variant Dust-tight:

Before attaching the sensor, remove the sealing bolts from the bracket. Before adjusting the control cam, unscrew the set-screw from the side cover.

Position "Gripper open" or "Part gripped (I.D. gripping)"

- Slide the sensor 1 (1) or sensor 2 (1) to the stop into the bracket (2).
- Tighten the screw (3) on the bracket (2).
Tightening torque: 0.2 Nm
- Open gripper or grip part.
- Undo the screw (4).
- Turn the screw (5) to push the position of the control cam (6).
 - ✓ Slide control cam (6) inwards until the sensor 1 (1) no longer responds.
Move the control cam (6) back towards the outside until the sensor 1 (1) begins to switch.

- Tighten screw (4) and in doing so press the control cam in the direction of the gripper fingers. **NOTICE! The control cam may tilt in the guide if it has not been tightened properly.**
 - ✓ Switching point is set.
- Bring product into the "Gripper open" or "Part gripped" position and test the function.

NOTE

If the switching position cannot be queried, it may be that the alignment of the control cam has to be changed, [Turn control cam](#) [▶ 29].

Position "Gripper closed" or "Part gripped (O.D. gripping)"

- Slide the sensor 3 (1) to the stop into the bracket (2).
- Tighten the screw (3) on the bracket (2).
Tightening torque: 0.2 Nm
- Close gripper or grip part.
- Undo the screw (4).
- Turn the screw (5) to push the position of the control cam (6).
 - ✓ Slide control cam (6) outwards until the sensor 3 (1) no longer responds.
Move the control cam (6) back towards the inside until the sensor 3 (1) begins to switch.
- Tighten screw (4) and in doing so press the control cam in the direction of the gripper fingers. **NOTICE! The control cam may tilt in the guide if it has not been tightened properly.**
 - ✓ Switching point is set.
- Bring product into the "Gripper closed" or "Part gripped" position and test the function.

NOTE

If the switching position cannot be queried, it may be that the alignment of the control cam has to be changed, [Turn control cam](#) [▶ 29].

Variant Dust-tight:

Screw in set-screw into the side cover.

5.3.11 Mounting flexible position sensor FPS

The flexible position sensor FPS consists of an evaluation unit and the sensor FPS-S-M8.

NOTICE

Risk of damage to the sensor during assembly!

- Observe the maximal tightening torque.

To be able to mount the sensor, the gripper has to be retrofitted with a special mounting kit.

Variant Dust-tight:

Before attaching the sensor, remove the sealing bolts from the bracket. Before adjusting the control cam, unscrew the set-screw from the side cover.

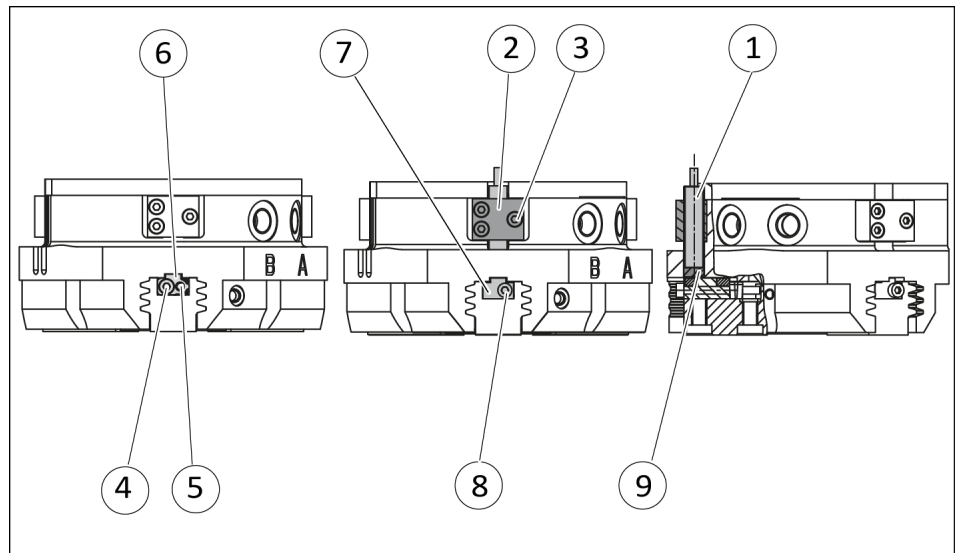

- Move product to the "gripper open" position.
- Loosen screw (4) and remove control cam (6) for the inductive monitoring from the base jaw.
- Remove screw (5) from the base jaw.
- Slide control cam (7) from the mounting kit with the recess at the front into the base jaw.
- Screw the control cam (7) to the base jaw using the screw (8).
- Slide spacer shim (9) into the bracket (2) to the stop.
- Slide the sensor (1) to the stop into the bracket (2).
- Tighten the screw (3) on the bracket (2).
Tightening torque: 0.2 Nm
- Adjust sensor (1), see assembly and operating manual of the sensor.

Variant Dust-tight:

Screw in set-screw into the side cover.

5.3.12 Mounting the analog position sensor APS-M1

To be able to mount the sensor, the gripper has to be retrofitted with a special mounting kit.

NOTICE

Blockade of the gripper after setting or replacing of the switching cam!

The switching cam can be tilt in the guide, if it was not fixed exactly in the base jaw.

- Apply the switching cam in the direction of the base jaw, so that the cam does not contact the housing of the gripper.

Variant Dust-tight:

Before attaching the sensor, remove the sealing bolts from the bracket. Before adjusting the control cam, unscrew the set-screw from the side cover.

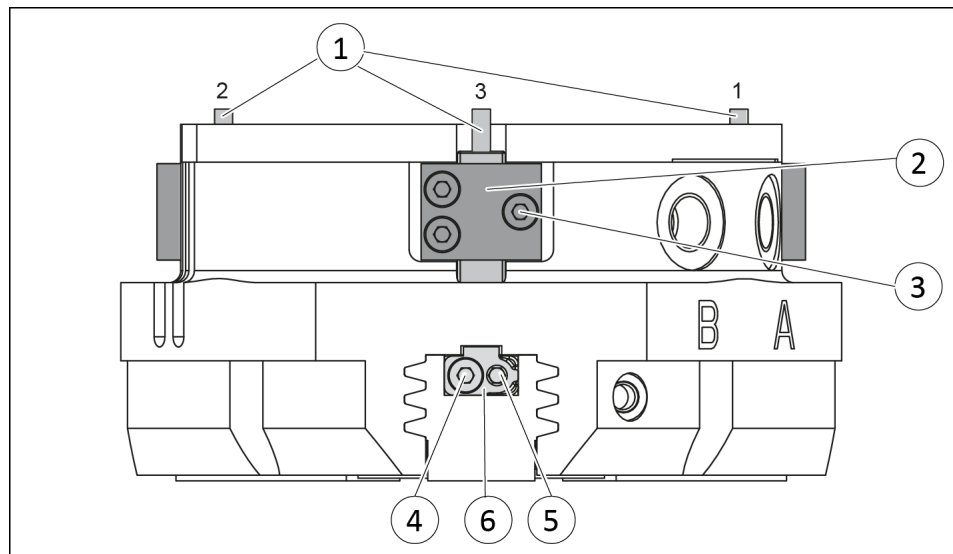

- Move product to the "gripper open" position.
- Loosen screw (4) and remove control cam (6) for the inductive monitoring from the base jaw.
- Apply adhesive to the top and sides of the control cam (6) from the mounting kit.
 - ✓ Make sure that there is no adhesive on the bottom of the control cam (6), which comes into contact with the sensor.
 - ✓ SCHUNK recommends the adhesive Loctite 290 or 638.

- Slide control cam (6) out of the mounting kit front into the base jaw.
 - ✓ Ensure that the higher front side of the control cam (6) is pointing outwards.
- Tighten screw (4) slightly.
- Turn the screw (5) to push the position of the control cam (6).
- Tighten screw (4) and in doing so press the control cam (6) in the direction of the gripper finger.
- Slide the sensor (1) to the stop into the bracket (2).
- Tighten the screw (3) on the bracket (2).
Tightening torque: 0.2 Nm
- Adjust sensor (1), see assembly and operating manual of the sensor.

Variant Dust-tight:

Screw in set-screw into the side cover.

5.3.13 Mounting the analog position sensor APS-Z80

To be able to mount the sensor, the gripper has to be retrofitted with a special mounting kit.

NOTICE

Blockade of the gripper after setting or replacing of the switching cam!

The switching cam can be tilt in the guide, if it was not fixed exactly in the base jaw.

- Apply the switching cam in the direction of the base jaw, so that the cam does not contact the housing of the gripper.

Variant Dust-tight:

Before attaching the sensor, remove the sealing bolts from the bracket. Before adjusting the control cam, unscrew the set-screw from the side cover.

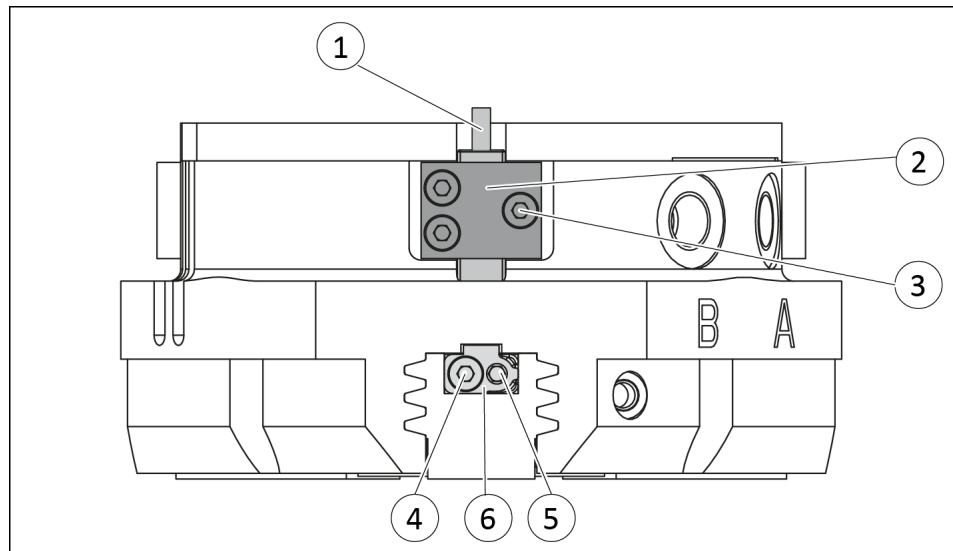

- Move product to the "gripper open" position.
- Loosen screw (4) and remove control cam (6) for the inductive monitoring from the base jaw.
- Remove screw (5) from the base jaw.
- Apply adhesive to the top and sides of the control cam (6) from the mounting kit.
 - ✓ Make sure that there is no adhesive on the bottom of the control cam (6), which comes into contact with the sensor.
 - ✓ SCHUNK recommends the adhesive Loctite 290 or 638.
- Slide control cam (6) into the base jaw to the stop.
 - ✓ Ensure that the higher front side of the control cam (6) is pointing outwards.
- **NOTICE! The control cam (6) must no longer move after it is screwed on.**
 - Screw the control cam (6) to the base jaw using the screw (5).
 - ✓ Secure the screw (5) with medium-strength locking liquid.
- Slide the sensor (1) to the stop into the bracket (2).
- Tighten the screw (3) on the bracket (2).
 - Tightening torque: 0.2 Nm
- Adjust sensor (1), see assembly and operating manual of the sensor.

Variant Dust-tight:

Screw in set-screw into the side cover.

5.3.14 Mounting the radio system RSS-R1/T2

The radio system RSS-R1/T2 can be used with the following sensors:

Assembly

- Reed switch RMS 80
- Install the sensor, [Mounting the reed switch RMS 80](#) [▶ 36].
- Adjust the sensor, see the assembly and operating manual for the sensor.
- Connect the radio system, see the assembly and operating manual for the radio system.

5.3.15 Mounting FMS force-measuring jaw

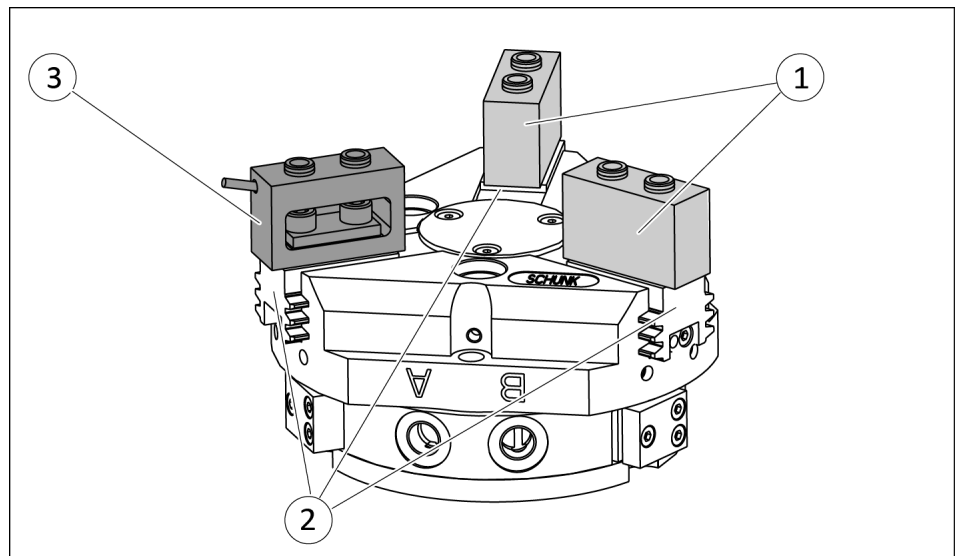

- Screw passive force-measuring jaw (1) and active force-measuring jaw (3) onto the base jaw (2).
 - ✓ Use centering sleeves between force-measuring jaw and intermediate jaw.
- Screw gripper fingers onto the force-measuring jaws (1, 3).
 - ✓ Use centering sleeves between force-measuring jaw and gripper finger.
- Connect the evaluation unit, see the Assembly and Operating Manual for the sensor.

6 Troubleshooting

6.1 Product is not moving

Possible cause	Corrective action
Base jaws jam in housing, e.g. mounting surface is not sufficiently even.	Check the evenness of the mounting surface. Mechanical connection [▶ 21]
	Loosen the mounting screws of the product and actuate the product again.
Pressure drops below minimum.	Check air supply. Pneumatic connection [▶ 25]
Compressed air lines switched.	Check compressed air lines. Pneumatic connection [▶ 25]
Proximity switch defective or set incorrect.	Readjust or change sensor.
Unused air connections open.	Close unused air connections.
Flow control valve closed.	Open the flow control valve.
Component part defective.	Replace component or send it to SCHUNK for repair.

6.2 Product is not executing the complete stroke

Possible cause	Corrective action
Dirt deposits between cover and piston.	Clean and if necessary re-lubricate. Maintenance [▶ 45]
Dirt deposits between basic jaws and guidance.	Disassemble and clean the product.
Pressure drops below minimum.	Check air supply. Pneumatic connection [▶ 25]
Mounting surface is not sufficiently flat.	Check the evenness of the mounting surface. Mechanical connection [▶ 21]
Component part defective.	Replace component or send it to SCHUNK for repair.

6.3 Product opens or closes abruptly

Possible cause	Corrective action
Too little grease in the mechanical guiding areas.	Clean and lubricate product. Maintenance [▶ 45]
Compressed air lines blocked.	Check compressed air lines of damage.
Mounting surface is not sufficiently flat.	Check the evenness of the mounting surface.
One-way flow control valve is missing or adjustet incorrectly.	Install and adjust one-way flow control valve.
Loading too large.	Check permissible weight and length of the gripper fingers.

6.4 Gripping force is dropping

Possible cause	Corrective action
Compressed air can escape.	Check seals, if necessary, disassemble the product and replace seals.
Too much grease in the mechanical movement space.	Clean and lubricate product. Maintenance [▶ 45]
Pressure drops below minimum.	Check air supply. Pneumatic connection [▶ 25]
Component part defective.	Replace component or send it to SCHUNK for repair.

6.5 Product does not achieve the opening and closing times

Possible cause	Corrective action
Compressed air lines are not installed optimally.	If present: Open the flow control couplings on the product to the maximum that the movement of the jaws occurs without bouncing and hitting.
	Check compressed air lines.
	Inner diameters of compressed air lines are of sufficient size in relation to compressed air consumption.
	Keep compressed air lines between the product and directional control valve as short as possible.
	Flow rate of valve is sufficiently large relative to the compressed air consumption.
	NOTICE! The throttle check valve must not be removed, even if the product has not reached the opening and closing times.
	If, despite optimum air connections, the opening and closing times specified in the catalogue are not achieved, SCHUNK recommends the use of quick-air-vent-valves directly at the product.
Loading too large.	Check permissible weight and length of the gripper fingers.

6.6 Programmable magnetic switches not switching as desired

Possible cause	Corrective action
Incorrect position of sensor	Check adjustment dimensions, Setting dimensions for magnetic switches [▶ 27].
Magnetic field too weak	Check function of sensor in both grooves.

7 Maintenance

7.1 Notes



⚠ DANGER

Danger of explosion in potentially explosive areas!

- Observe supplementary sheet for products with explosion-resistant versions "PZN-plus -...-EX".



⚠ WARNING

Risk of burns through contact with hot surfaces!

Surfaces of components can heat up severely during operation. Skin contact with hot surfaces causes severe burns to the skin.

- For all work in the vicinity of hot surfaces, wear safety gloves.
- Before carrying out any work, make sure that all surfaces have cooled down to the ambient temperature.

Original spare parts

Use only original spare parts of SCHUNK when replacing spare and wear parts.

Exchange of housing and base jaws

The base jaws and the guidance in the housing are matched. To exchange these parts, send the product with a repair order to SCHUNK or order the housing with the base jaws as a set.

Maintenance of version with gripping force maintenance I.D. gripping and O.D. gripping

The pistons have to be aligned using an assembly device. Therefore we recommend to have the module serviced and the seals replaced by SCHUNK.

7.2 Maintenance intervals

NOTICE

Material damage due to hardening lubricants!

Lubricants harden more quickly at temperatures above 60°C, leading to possible product damage.

- Reduce the lubricant intervals accordingly.

Interval (million cycles) for PZN-plus			Maintenance work
40 - 160	200 - 300	380	
10	5	0.05	Clean all parts thoroughly, check for damage and wear, if necessary replace seals and wearing parts, Disassembly and assembly [▶ 48]. The seals are in the enclosed sealing kit., Sealing kit [▶ 9].
10	5	0.05	Treat all grease areas with lubricant, Lubricants/greasing areas (basic lubrication) [▶ 47]. Oil or grease bare outside steel parts.

7.3 Lubricants/greasing areas (basic lubrication)

SCHUNK recommends the lubricants listed.

During maintenance, treat all greased areas with lubricant. Thinly apply lubricant with a lint-free cloth.

Lubricant point	Lubricant
Metallic sliding surfaces	microGLEIT GP 360
All seals	Renolit HLT 2
Bore hole at the piston	Renolit HLT 2

PZN-plus 40 - 300

Depending on the load, the guides in the housing can be re-lubricated.

PZN-plus 380

The lubrication is made via the lubricating nipples on the lubricating hole. The other lubricating holes must be closed with a grub screw. Therefore 15 ml of the lubricant have to be pumped in the gripper using the lubricating nipples. After the lubricating process, remove the lubricating nipples and close the lubricating hole with a grub screw.

All other lubrication points like seal and hole at the piston must be relubricated every 1 million cycles. Therefore the gripper must be disassembled.

7.4 Disassembly and assembly

7.4.1 Variant with dust cover

Position of the item numbers [Variant with dust cover](#) [► 59]

The dust cover has to be removed in advance for versions with a dust cover

- Unscrew and remove the screws (92) and remove the washers (93) and the centering sleeves (86). Items 92 and 93 are only used for securing devices for transportation.
- Pull out the intermediate jaws (84) upwards and remove the O-rings (87) and the intermediate plates (83).
- Undo the countersunk screws (89) and remove the cover plate (82).
- Unscrew the screws (90) and remove the covers (81).

7.4.2 Version without gripping force maintenance

Position of the item numbers [Drawings](#) [► 57]



⚠ WARNING

Risk of injury due to unexpected movements!

If the power supply is switched on or residual energy remains in the system, components can move unexpectedly and cause serious injuries.

- Before starting any work on the product: Switch off the power supply and secure against restarting.
- Make sure, that no residual energy remains in the system.



⚠ WARNING

In the case of the version with the pressure piece, the pressure piece is spring-loaded!

- Remove air pressure lines.
- Carefully undo the set-screw (74) and pull out the pressure piece.
- Undo the screws (47) and then remove the cover plate (5).
- Mark the installation position for the piston (3/8) and the base jaw in the housing.
- Undo the screws (41) and then remove the cover (4).
- Mark the installation position between the cylinder piston (60) and the housing (1). Fully undo the screw (40) and remove the cylinder piston (60) from the housing (1).

- Push the piston (3 / 8) upwards and out of the housing (1).
- Pull the base jaw (2 / 7) out of the housing (1).

7.4.3 Version with gripping force maintenance O.D.

Position of the item numbers [Drawings](#) [▶ 57]



⚠ WARNING

Danger due to very high spring forces!

- With regard to size PZN-plus 240, 300 and 380 with gripping force maintenance, we urgently recommend that you get SCHUNK to disassemble the gripper for the purpose of maintenance and seal replacement



⚠ WARNING

Risk of injury due to spring forces!

When disassembling, the cover and the cylinder piston can be thrown out by high spring forces.

- Secure the cover from being ejected during disassembly (e.g. in a press)



⚠ WARNING

Risk of injury due to unexpected movements!

If the power supply is switched on or residual energy remains in the system, components can move unexpectedly and cause serious injuries.

- Before starting any work on the product: Switch off the power supply and secure against restarting.
- Make sure, that no residual energy remains in the system.

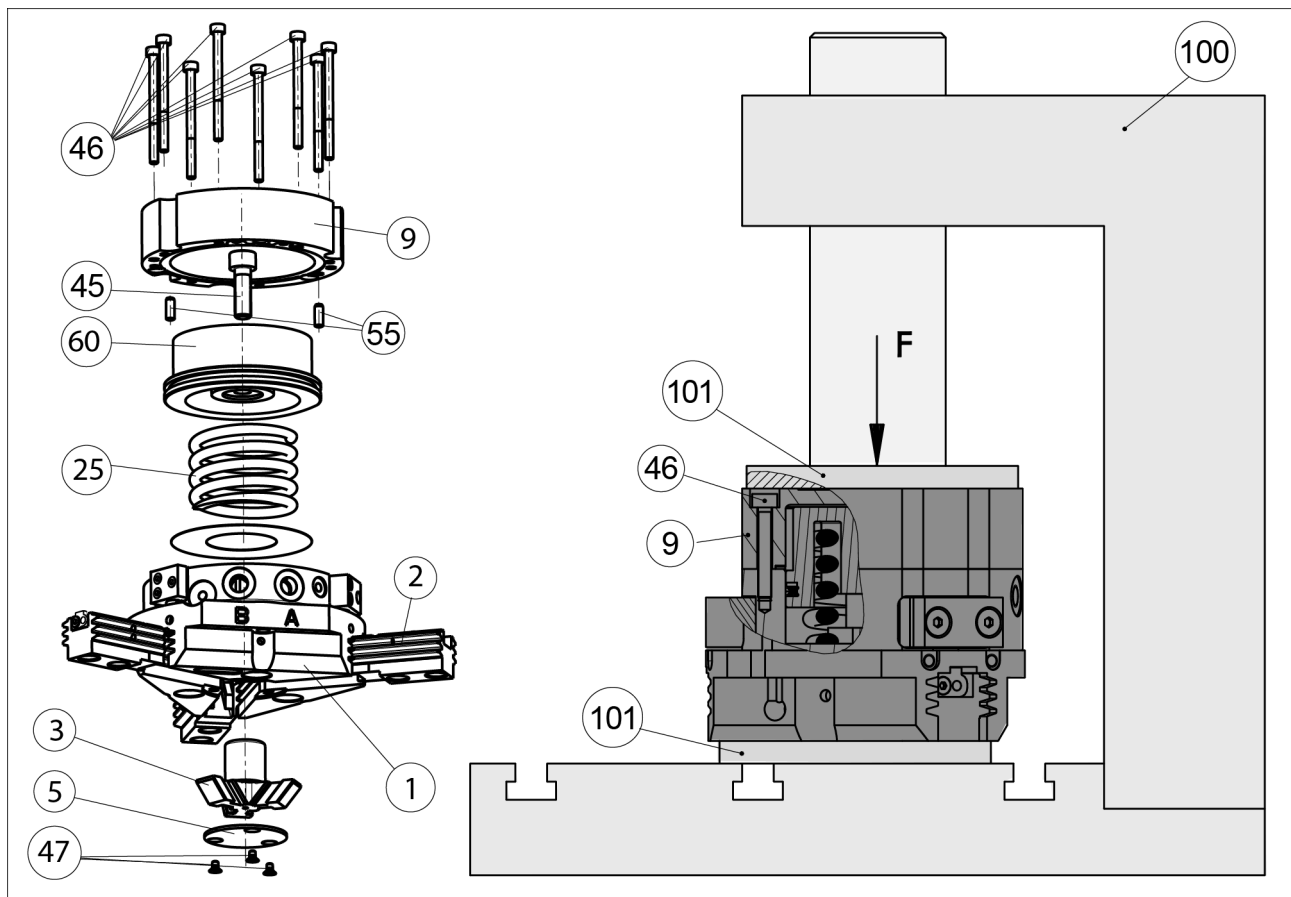

- Remove the compressed air lines.
- Unscrew the screws (47) and remove the cover plate (5).
- Mark the installation position of the piston (3) and the base jaws (2) in the housing (1).
- Clamp the gripper with suitable plastic base (101) between the base jaws (2) and the cover (9) in a press (100), so that the 8 screws (46) still can be removed.
- Unscrew the screws (46).
- Open press (100) carefully.
- Remove the cover (5).
- Remove centering pins (55).

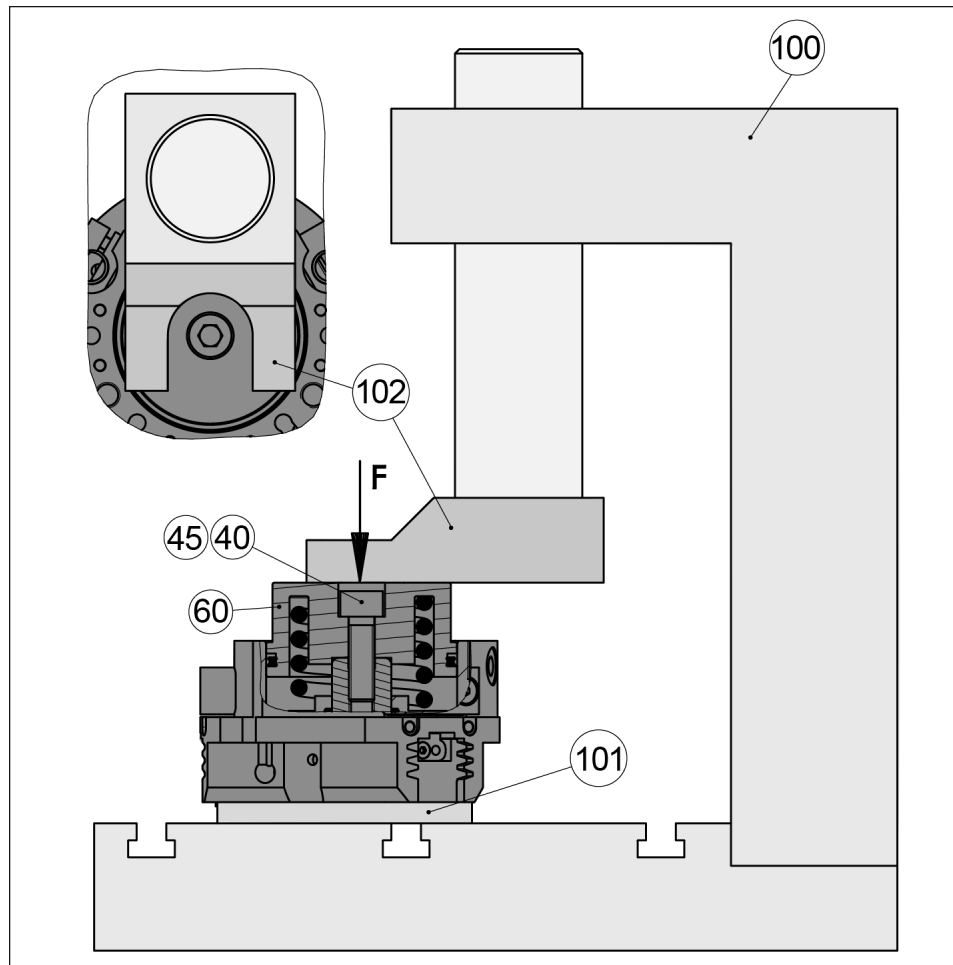

- Mark the installation position of the piston (60) and housing (1) (observe position of the magnet).
- Clamp the gripper between the base jaws (2) on the cylinder piston (60) in a press (100) with compression die (102) (mounting force F: [Spring force information for assembly](#) [▶ 57]).
- Undo the screw (45) and then carefully open the press (100) until the compression spring is fully extended.
- Remove the cylinder piston (60) and the compression springs (25) from the housing (1).
- Push the piston (3) upwards and out of the housing (1).
- Pull the base jaws (2) out of the housing (1).

7.4.4 Version with gripping force maintenance I.D.



⚠ WARNING

Danger due to very high spring forces!

- With regard to size PZN-plus 240, 300 and 380 with gripping force maintenance, we urgently recommend that you get SCHUNK to disassemble the gripper for the purpose of maintenance and seal replacement!



⚠ WARNING

Risk of injury due to spring forces

When disassembling, the cover can be thrown out by high spring forces.

- Secure the cover from being ejected during disassembly (e.g. in a press)



⚠ WARNING

Risk of injury due to unexpected movements!

If the power supply is switched on or residual energy remains in the system, components can move unexpectedly and cause serious injuries.

- Before starting any work on the product: Switch off the power supply and secure against restarting.
- Make sure, that no residual energy remains in the system.

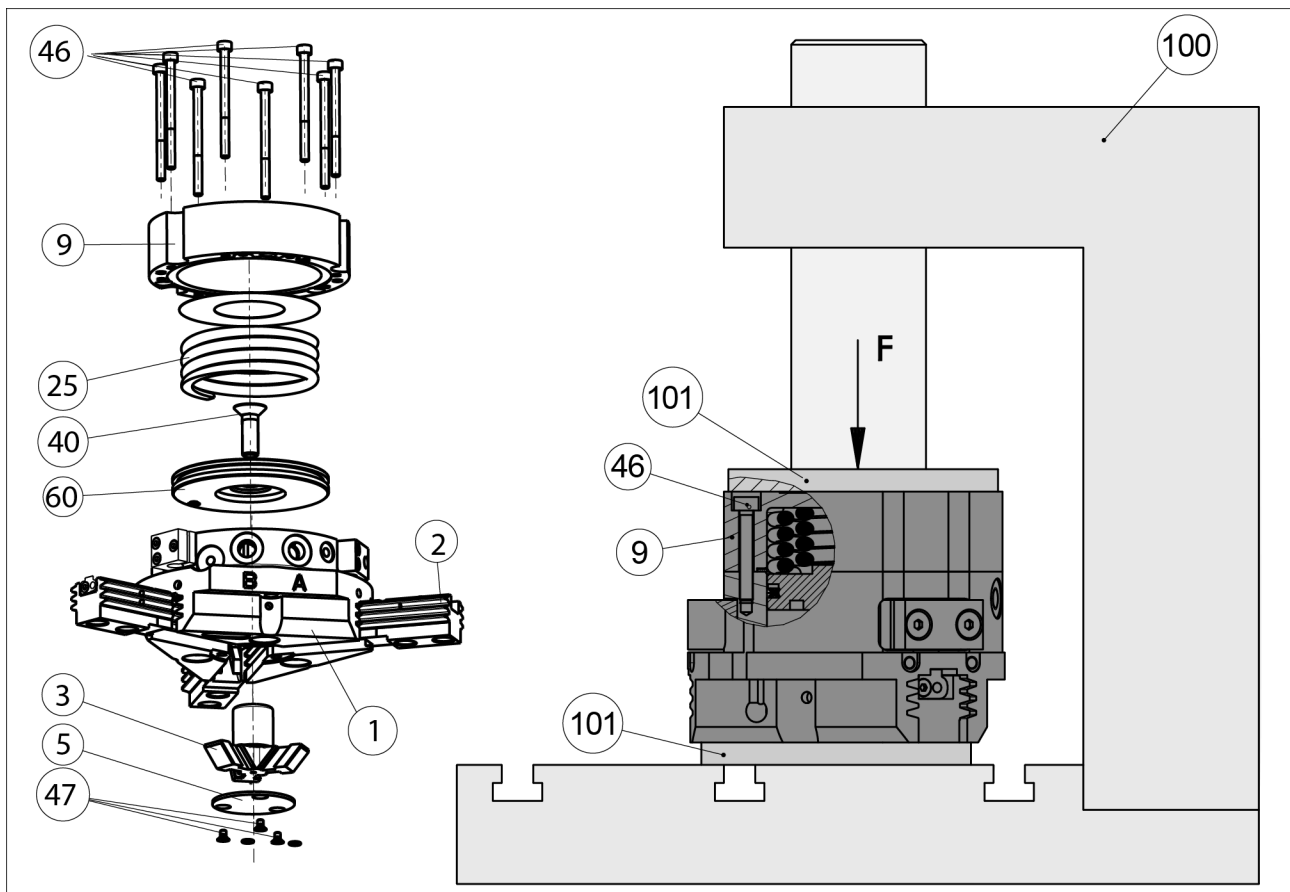

- Remove the compressed air lines.
- Undo the screws (47) and then remove the cover plate (5).
- Mark the installation position for the piston (3) and the base jaw (2) in the housing (1).
- Clamp the gripper with suitable plastic base (101) between the base jaws (2) and the cover (9) in a press (100), so that the screws (46) still can be removed.
- Unscrew the screws (46).
- Open press (100) carefully. until the compression spring is no longer under tension.
- Remove cover and compression springs.
- Mark the installation position for the piston (60) on the housing (1).
- Undo the screws (40)
- Remove the cylinder piston (60) out of the housing (1).
- Push the pistons (3) upwards out of the housing (1).
- Pull the base jaws (2) out of the housing (1).

7.4.5 Version with force amplification cylinder (KVZ)



⚠ WARNING

Danger due to very high spring forces!

- With regard to size PZN-plus 240, 300 and 380 with gripping force maintenance, we urgently recommend that you get SCHUNK to disassemble the gripper for the purpose of maintenance and seal replacement



⚠ WARNING

Risk of injury due to spring forces

When disassembling, the cover can be thrown out by high spring forces.

- Secure the cover from being ejected during disassembly (e.g. in a press)



⚠ WARNING

Risk of injury due to unexpected movements!

If the power supply is switched on or residual energy remains in the system, components can move unexpectedly and cause serious injuries.

- Before starting any work on the product: Switch off the power supply and secure against restarting.
- Make sure, that no residual energy remains in the system.



⚠ WARNING

For the version with pressure piece, the spring-loaded pressure piece is under spring tension!

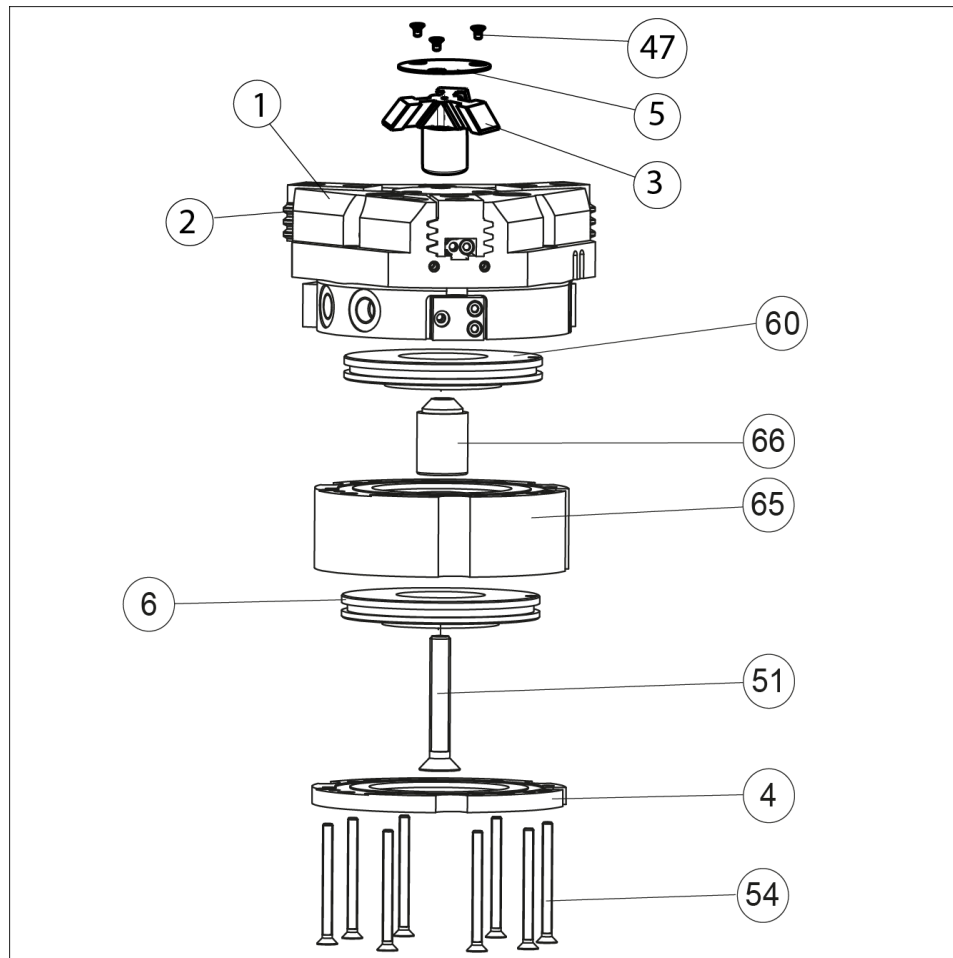

- Remove air pressure lines.
- Undo the screws (47) and then remove the cover plate (5).
- Mark the installation position for the piston (3) and the base jaw (2) in the housing (1).
- **Version with gripping force maintenance (A.D.) or (O.D.):** As described in the previous chapters [Version with gripping force maintenance O.D. \[▶ 49\]](#)/[Version with gripping force maintenance I.D. \[▶ 52\]](#), clamp the gripper into a press and remove the screws (54).
- **Version without gripping force maintenance:** Remove the screws (54) and then remove the cover (4).
- Unscrew the screw (51) and remove the cylinder piston (6) and the spacer piston (66) from the intermediate housing (65).
- Remove the intermediate housing (65).
- Mark the installation position between the cylinder piston (60) and the housing (1). Remove the cylinder piston (60) from the housing (1).
- Push the piston (3) upwards and out of the housing (1).
- Pull the base jaws (2) out of the housing (1).

7.4.6 Notes for assembly

Assembly takes place in the opposite order to disassembly.
Observe the following:

- Unless otherwise specified, secure all screws and nuts with Loctite no. 243 and tighten with the appropriate tightening torque. [Screw tightening torques](#) [▶ 57]
- For variant with gripping force maintenance: assemble cylinder piston using a press, [Version without gripping force maintenance](#) [▶ 48].
- During assembly, observe the spring forces, [Spring force information for assembly](#) [▶ 57]

7.4.7 Screw tightening torques

Position of the item numbers [Drawings](#) [▶ 57]

Tightening torque [Nm]

Item	Size										
	40	50	64	80	100	125	160	200	240	300	380
40	2.2	5.9	12	12	20	49	96	150	150	250	415
41	0.45	1.2	1.2	1.3	1.3	2.9	8.5	20	20	35	58
45	4.9	10	14	14	29	57.5	96	200	200	250	692
46	0.45	1.2	1.2	1.3	2.9	6	10	25	25	50	50
51	-	-	12	12	20	49	96	-	-	-	-

7.4.8 Spring force information for assembly

	Size										
	40	50	64	80	100	125	160	200	240	300	380
with gripping force maintenance O.D. gripping											
preload [mm]	14	6	15	27	24	29	47	55	25	90	47
spring force [N]	174	132	261	496	875	1253	2372	4982	5016	9465	10130
with gripping force maintenance I.D. gripping											
preload [mm]	10	14	46	36	46	71	96	100	48	100	63
spring force [N]	111	183	388	701	1389	2037	3927	7373	6267	13464	14163

7.5 Drawings

The following figures are example images.

They serve for illustration and assignment of the spare parts.

Variations are possible depending on size and variant.

7.5.1 Basic module

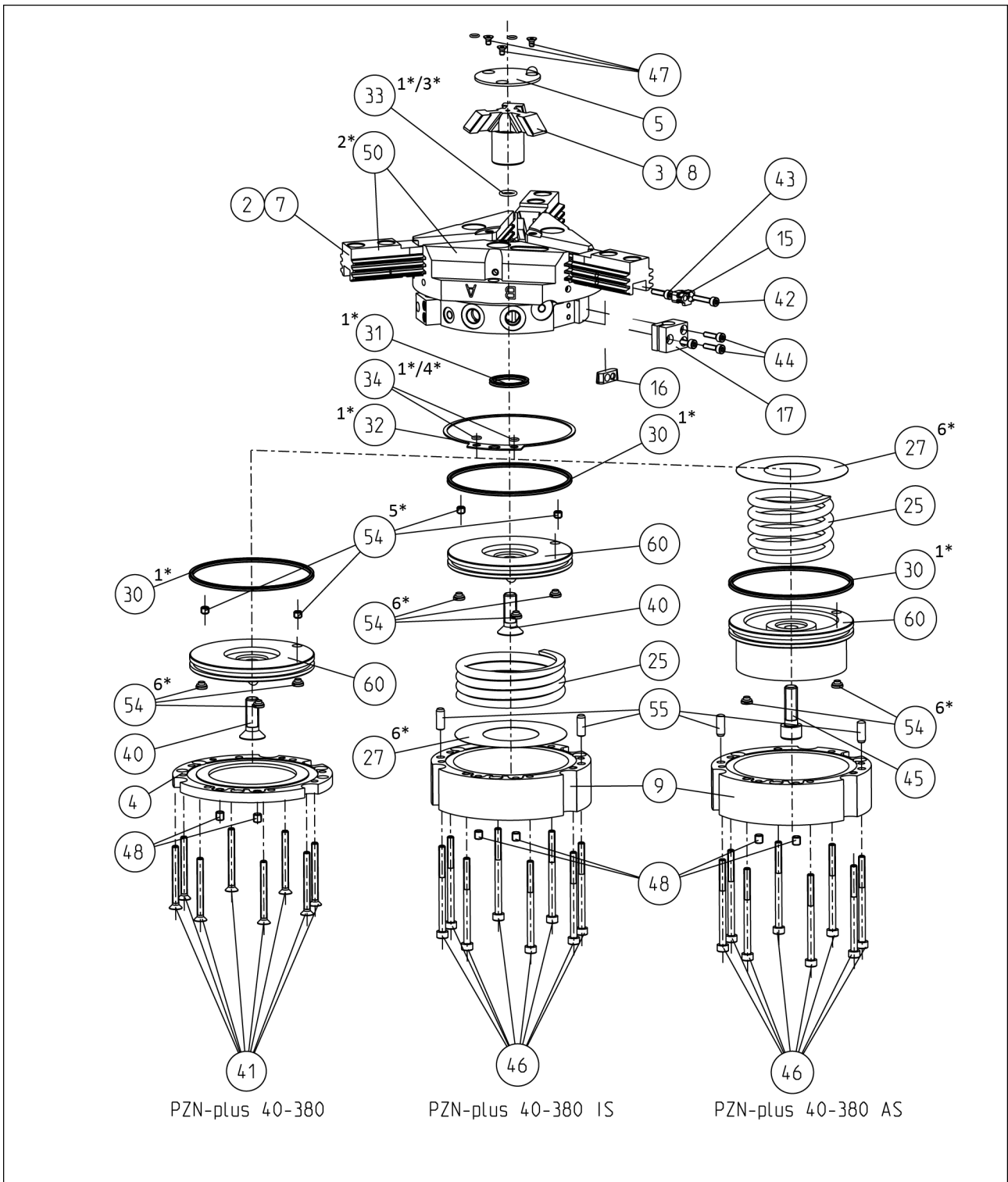

Assembly of the variants "O.D. gripping" / "I.D. gripping" / without gripping force maintenance

- 1* Wearing part, replace during maintenance.
Included in the seal kit. Seal kit can only be ordered completely.
- 2* Positions are adapted to each other and can not be replaced by the customer.
- 3* not for PZN-plus 40 - 125
- 4* from size PZN-plus 125

7.5.2 Variant with dust cover

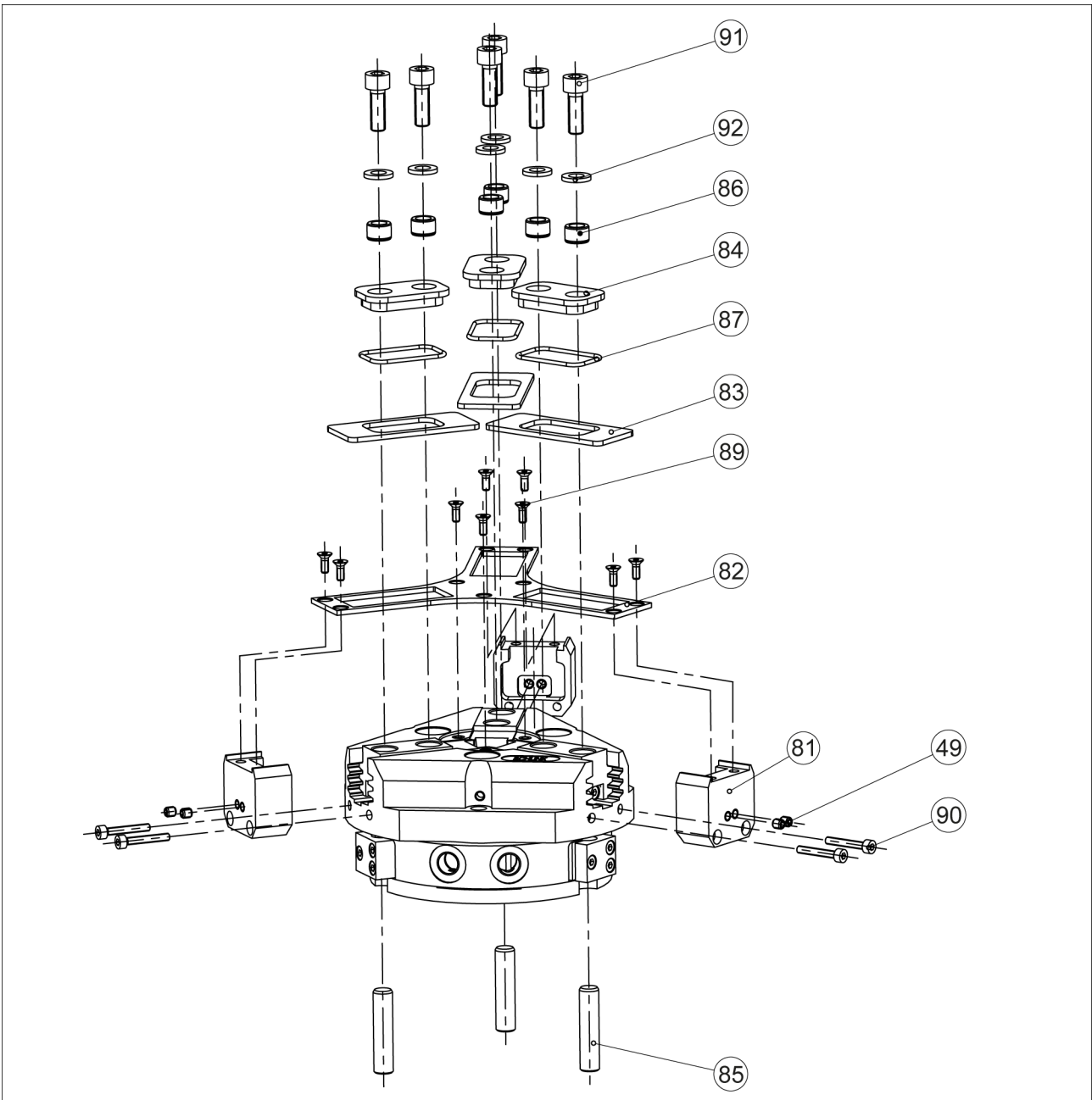

7.5.3 Variant with force amplification cylinder

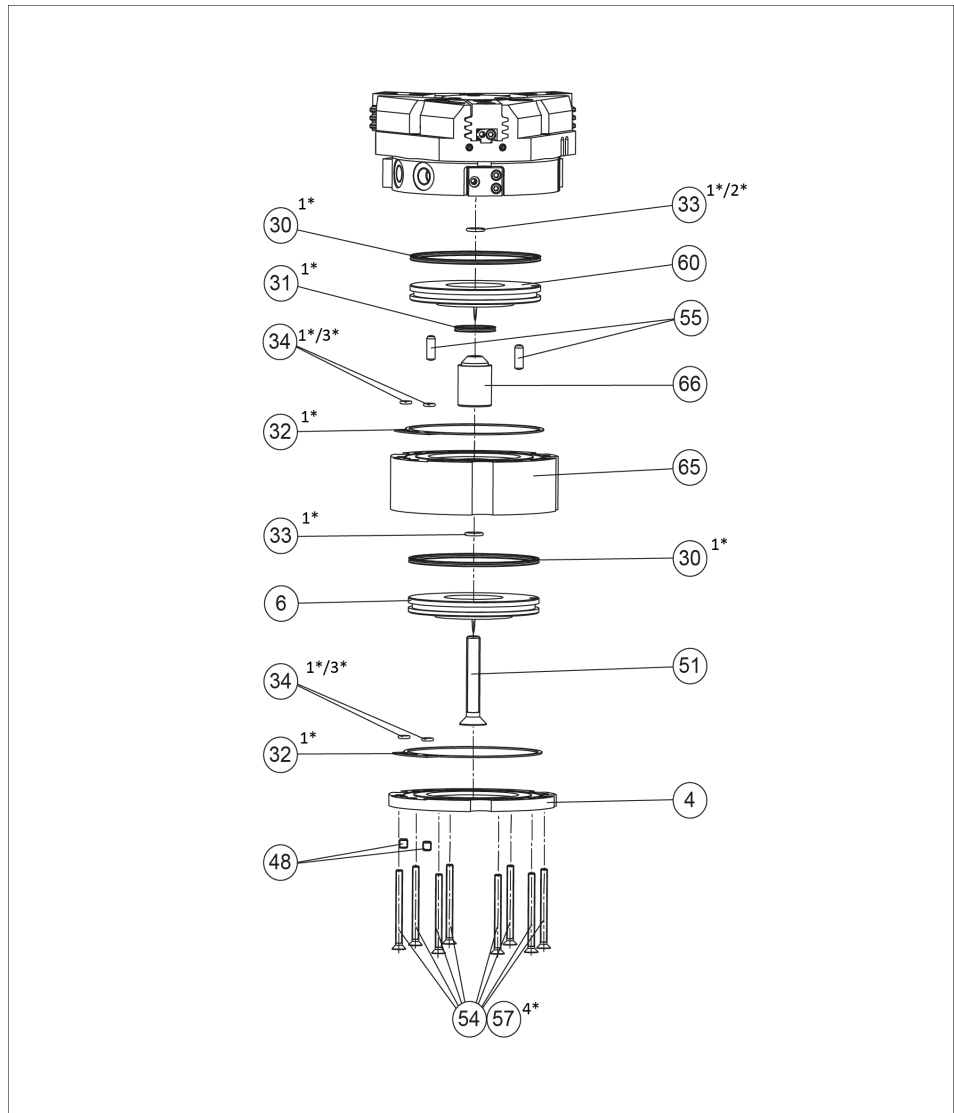

1*	Wearing part, replace during maintenance. Included in the seal kit. Seal kit can only be ordered completely.
2*	not for PZN-plus 64 - 125
3*	from size PZN-plus 125
4*	from size PZN-plus 160

8 Translation of original declaration of incorporation

in terms of the Directive 2006/42/EG, Annex II, Part 1.B of the European Parliament and of the Council on machinery.

Manufacturer/
Distributor SCHUNK GmbH & Co. KG Spann- und Greiftechnik
Bahnhofstr. 106 – 134
D-74348 Lauffen/Neckar

We hereby declare that on the date of the declaration the following partly completed machine complied with all basic safety and health regulations found in the directive 2006/42/EC of the European Parliament and of the Council on machinery. The declaration is rendered invalid if modifications are made to the product.

Product designation: 3-Finger Centric Gripper / PZN-plus / pneumatic
ID number 0303308 ... 0303648

The partly completed machine may not be put into operation until conformity of the machine into which the partly completed machine is to be installed with the provisions of the Machinery Directive (2006/42/EC) is confirmed.

Applied harmonized standards, especially:

EN ISO 12100:2010 Safety of machinery - General principles for design -
Risk assessment and risk reduction

The manufacturer agrees to forward on demand the relevant technical documentation for the partly completed machinery in electronic form to national authorities.

The relevant technical documentation according to Annex VII, Part B, belonging to the partly completed machinery, has been created.

Person authorized to compile the technical documentation:
Robert Leuthner, Address: see manufacturer's address

Signature: see original declaration

Lauffen/Neckar, April 2019

p.p. Ralf Winkler,
Manager for development of
gripping system components

9 Annex to Declaration of Incorporation

according 2006/42/EG, Annex II, No. 1 B

1. Description of the essential health and safety requirements pursuant to 2006/42/EC, Annex I that are applicable and that have been fulfilled with:

Product designation	3-Finger Centric Gripper
Type designation	PZN-plus
ID number	0303308 ... 0303648

To be provided by the System Integrator for the overall machine	↓
Fulfilled for the scope of the partly completed machine	↓
Not relevant	↓

1.1	Essential Requirements			
1.1.1	Definitions		X	
1.1.2	Principles of safety integration		X	
1.1.3	Materials and products		X	
1.1.4	Lighting		X	
1.1.5	Design of machinery to facilitate its handling		X	
1.1.6	Ergonomics		X	
1.1.7	Operating positions			X
1.1.8	Seating			X

1.2	Control Systems			
1.2.1	Safety and reliability of control systems		X	
1.2.2	Control devices		X	
1.2.3	Starting		X	
1.2.4	Stopping		X	
1.2.4.1	Normal stop		X	
1.2.4.2	Operational stop		X	
1.2.4.3	Emergency stop		X	
1.2.4.4	Assembly of machinery		X	
1.2.5	Selection of control or operating modes		X	
1.2.6	Failure of the power supply			X

1.3	Protection against mechanical hazards			
1.3.1	Risk of loss of stability			X
1.3.2	Risk of break-up during operation			X
1.3.3	Risks due to falling or ejected objects			X
1.3.4	Risks due to surfaces, edges or angles		X	

1.3	Protection against mechanical hazards			
1.3.5	Risks related to combined machinery			X
1.3.6	Risks related to variations in operating conditions			X
1.3.7	Risks related to moving parts		X	
1.3.8	Choice of protection against risks arising from moving parts			X
1.3.8.1	Moving transmission parts		X	
1.3.8.2	Moving parts involved in the process			X
1.3.9	Risks of uncontrolled movements			X
1.4	Required characteristics of guards and protective devices			
1.4.1	General requirements			X
1.4.2	Special requirements for guards			X
1.4.2.1	Fixed guards			X
1.4.2.2	Interlocking movable guards			X
1.4.2.3	Adjustable guards restricting access			X
1.4.3	Special requirements for protective devices			X
1.5	Risks due to other hazards			
1.5.1	Electricity supply		X	
1.5.2	Static electricity		X	
1.5.3	Energy supply other than electricity		X	
1.5.4	Errors of fitting		X	
1.5.5	Extreme temperatures			X
1.5.6	Fire			X
1.5.7	Explosion			X
1.5.8	Noise			X
1.5.9	Vibrations			X
1.5.10	Radiation	X		
1.5.11	External radiation	X		
1.5.12	Laser radiation	X		
1.5.13	Emissions of hazardous materials and substances			X
1.5.14	Risk of being trapped in a machine	X		
1.5.15	Risk of slipping, tripping or falling	X		
1.5.16	Lightning			X
1.6	Maintenance			
1.6.1	Machinery maintenance		X	
1.6.2	Access to operating positions and servicing points		X	
1.6.3	Isolation of energy sources		X	
1.6.4	Operator intervention		X	
1.6.5	Cleaning of internal parts		X	

1.7	Information			
1.7.1	Information and warnings on the machinery		X	
1.7.1.1	Information and information devices		X	
1.7.1.2	Warning devices		X	
1.7.2	Warning of residual risks		X	
1.7.3	Marking of machinery	X		
1.7.4	Instructions	X		
1.7.4.1	General principles for the drafting of instructions	X		
1.7.4.2	Contents of the instructions	X		
1.7.4.3	Sales literature	X		
	The classification from Annex 1 is to be supplemented from here forward.			
2	Supplementary essential health and safety requirements for certain categories of machinery			X
2.1	Foodstuffs machinery and machinery for cosmetics or pharmaceutical products			X
2.2	Portable hand-held and/or guided machinery			X
2.2.1	Portable fixing and other impact machinery			X
2.3	Machinery for working wood and material with similar physical characteristics			X
3	Supplementary essential health and safety requirements to offset hazards due to the mobility of machinery		X	
4	Supplementary essential health and safety requirements to offset hazards due to lifting operations		X	
5	Supplementary essential health and safety requirements for machinery intended for underground work			X
6	Supplementary essential health and safety requirements for machinery presenting particular hazards due to the lifting of persons		X	