



Superior Clamping and Gripping



Product Information

Universal gripper PGN-plus-P 80

PGN-plus-P

Universal gripper

Reliable. Robust. Flexible.

Universal gripper PGN-plus-P

Universal 2-finger parallel gripper with permanent lubrication, high gripping force, and high maximum moments due to the use of a multi-tooth guidance.

Field of application

Pneumatic universal gripper for handling of workpieces in universal applications. For universal use in clean to slightly dirty environments. Special versions available for dirty environments.

Advantages – Your benefits

Robust multi-tooth guidance for precise handling

High maximum moments possible suitable for using long gripper fingers

Lubricant pockets in the multi-tooth guidance ensure process reliability and extended maintenance intervals

Maximum piston surface area for maximum gripping forces

Mounting from two sides in three screw directions for universal and flexible gripper assembly

Air supply via hose-free direct connection or screw connections for universal and flexible gripper assembly

Comprehensive sensor accessory program for versatile querying possibilities and stroke position monitoring

Manifold options for special optimization for your specific case of application (dustproof, high-temperature, corrosion-protected, etc.)



Sizes
Quantity: 11



Weight
0.08 .. 39.8 kg



Gripping force
180 .. 26100 N



Stroke per jaw
2 .. 45 mm



Workpiece weight
0.9 .. 97.5 kg

Functional description

The piston is moved up and down by compressed air. The angled active surfaces of the wedge-hook produce a synchronized, parallel jaw motion.

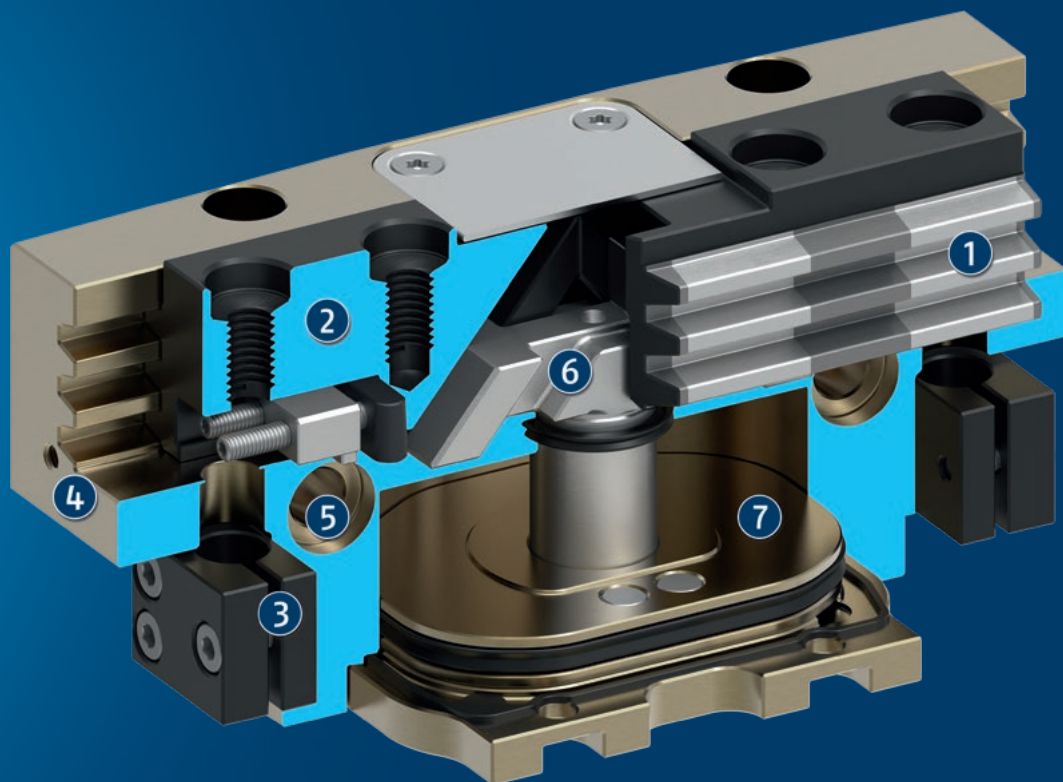

① Multi-tooth guidance

Maximum service life due to lubricant pockets in the robust multi-tooth guidance, and absorption of high forces and torques by means of the large guidance support

② Base Jaw

with standardized screw connection diagram for the connection of the workpiece-specific gripper fingers

③ Bracket for sensors

Brackets for proximity switches and adjustable control cams in the housing

④ Housing

is weight-optimized due to the use of high-strength aluminum alloy

⑤ Centering and mounting possibilities

for universal assembly of the gripper

⑥ Wedge-hook design

for high power transmission and minimal wear as a result of larger diagonal pull surfaces

⑦ Piston

Maximum force through maximum surface of drive piston

Detailed functional description

Dustproof version SD



The "dustproof" option increases the degree of protection against penetrating substances.

This can either be ordered in a ready-mounted gripper version or else retrofitted to the gripper using the "SAD PGN-plus-P" retrofit kit.

Gripping force maintenance version AS/IS

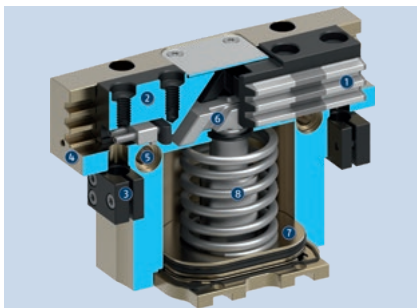

The mechanical gripping force maintenance device ensures that a minimum clamping force will be applied even if there is a drop in pressure. In the AS version this acts as a closing force, and in the IS version as an opening force. The image shows the AS version. The gripping force maintenance can also be used to increase the gripping force or for one-way gripping.

- ❶ Multi-tooth guidance
- ❷ Base Jaw
- ❸ Bracket for sensors
- ❹ Housing
- ❺ Centering and mounting possibilities
- ❻ Wedge-hook design
- ❼ Piston
- ❽ Gripping force maintenance device

Settings of the control cams during monitoring with inductive proximity switches

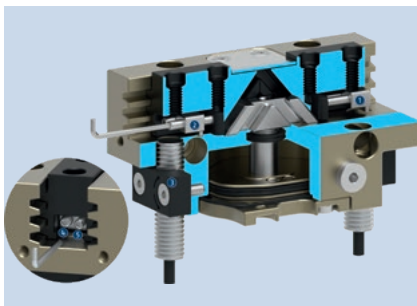

Monitoring with inductive proximity switch can be performed as standard from size 64. In delivery state, the positions "gripper open" and "gripper closed" are preset with the control cams. The inductive sensors must be ordered separately and are slid into the housing up to the stop and clamped.

In order to monitor any other position, such as "workpiece gripped" for example, both control cams can be individually set in the respective base jaws.

- ❶ Control cam preset for "gripper closed" position
- ❷ Control cam preset for "gripper open" position
- ❸ Holder with clamping screw for fixing the sensor
- ❹ Clamping screw for process-reliable fixing of the adjusted switching point
- ❺ Adjusting screw for setting any switching point

Optional mounting possibility under the cover sheet for customer-specific additional structure

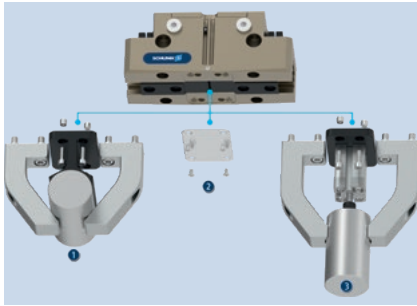

In delivery state, a cover sheet is mounted to the gripper. This can be removed if necessary. Under the cover sheet are threads and fittings for mounting customer-specific designs for implementing additional functions.

- ❶ Additional centering or support of the workpiece
- ❷ The cover plate (can be removed)
- ❸ Ejector with external cylinder attached to the gripper

PGN-plus-P

Universal gripper

General notes about the series

Operating principle: Wedge gear with surface power transmission

Housing material: Aluminum

Base jaw material: Steel

Actuation: pneumatic, with filtered compressed air as per ISO 8573-1:2010 [7:4:4].

Warranty: 36 months

Scope of delivery: Brackets for proximity switches, centering sleeves, O-rings for direct connection, assembly instructions (operating manual with declaration of incorporation is available online)

Gripping force maintenance device: possible by using the version with mechanical gripping force maintenance or pressure maintenance valve SDV-P

Gripping force: is the arithmetic sum of the individual force applied to each jaw at distance P (see illustration).

Finger length: is measured from the reference surface as the distance P in direction to the main axis.

The maximum permissible finger length applies until the nominal operating pressure is achieved. With higher pressures, the finger length must be reduced proportionally to the nominal operating pressure.

Repeat accuracy: is defined as a distribution of the end Position for 100 consecutive strokes.

Workpiece weight: is calculated for force-fit gripping with a coefficient of static friction of 0.1 and a safety factor of 2 against workpiece slippage at acceleration due to gravity g. For form-fit or capture gripping, there are significantly higher permissible workpiece weights.

Closing and opening times: are purely the times that the base jaws or fingers are in motion. Valve switching times, hose fill times, or PLC reaction times are not included, and are to be considered when cycle times are calculated.

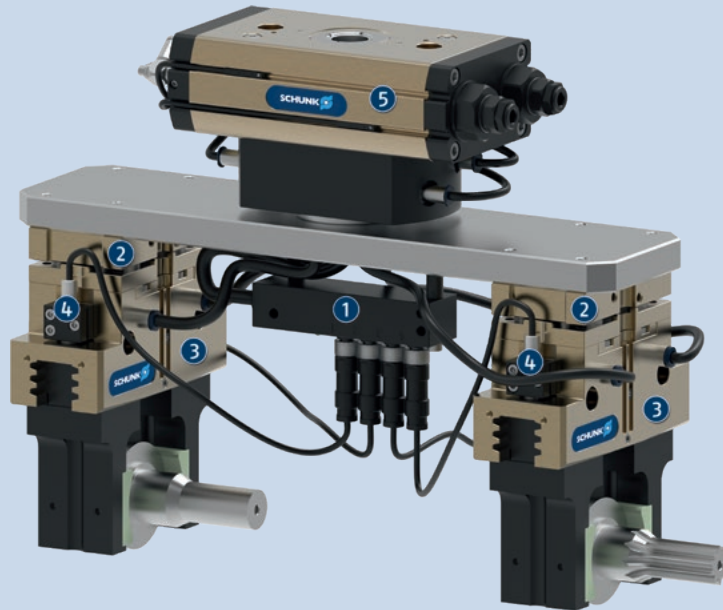

Application example

Handling tool for loading and unloading raw and finished parts and compensation of inaccurate position. A sensor distributor is used for routing signals through a cable.

- ① Sensor distributor V4
- ② Tolerance compensation unit TCU-Z
- ③ Universal gripper PGN-plus-P
- ④ IN sensors
- ⑤ Universal rotary actuator SRM

SCHUNK offers more ...

The following components make the product even more productive – the suitable addition for the highest functionality, flexibility, reliability, and controlled production.



Rotary unit



Quick change system



Compensation unit



Linear module



Jaw quick-change system



Finger blank



Pressure maintenance valve



Universal intermediate jaw



Flexible position sensor



Analog position sensor



Magnetic switches



Inductive proximity switches

① For more information on these products can be found on the following product pages or at schunk.com.

Options and special information

Gripping force maintenance version AS/IS: The mechanical gripping force maintenance version ensures minimum gripping force even in the event of a pressure drop. In the AS/IS version this acts as a closing force, in the IS version as an opening force.

High-temperature version VHT: for use in hot environments

Precision version P: for the highest accuracy

Anti-corrosion version K: for use in corrosion-inducing atmospheres

ATEX version EX: for explosive environments

Dustproof version SD: absolutely dustproof, increased degree of protection against ingress of materials.

Additional versions: Various options can be combined with each other.

Integrated air purge connection: impedes the ingress of dirt into the inside of the gripper

NEW: H1 grease version H1G: with H1 compliant lubrication as a solution for easy entry into medical technology, lab automation, the pharmaceutical industry and food industry

PGN-plus-P

Universal gripper

SCHUNK gripper PGN-plus-P

Overview Accessories

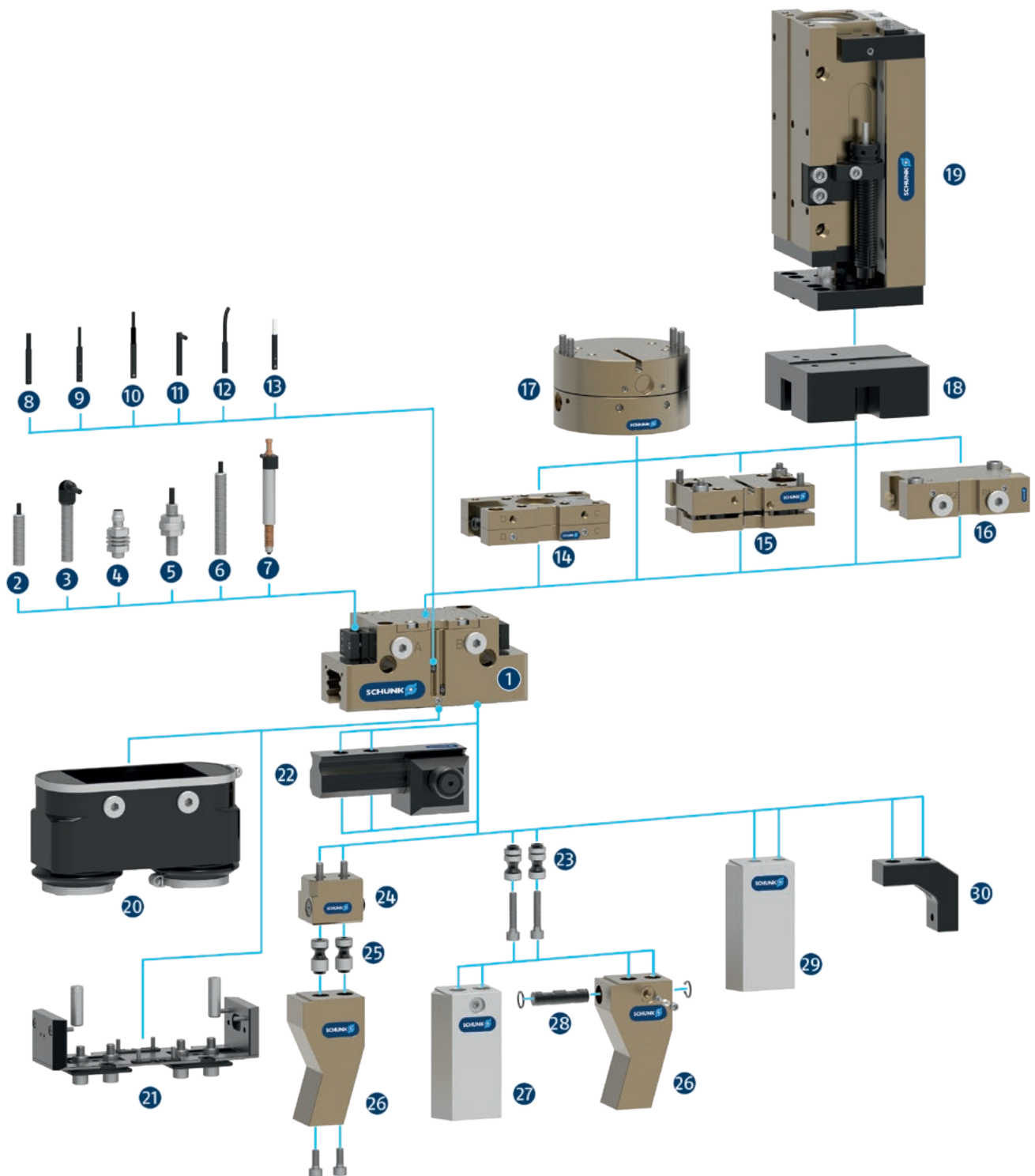

1 PGN-plus-P

Universal 2-finger parallel gripper with a high gripping force and high maximum moments due to the use of a multi-tooth guidance

Sensor system

2 IN ...

Inductive proximity switch with molded cable and straight cable outlet

3 IN ...-SA

Inductive proximity switch with molded cable and lateral cable outlet

4 IN-C 80

Inductive proximity switch, directly pluggable

5 FPS

Flexible position sensor for monitoring up to five different, freely selectable positions

6 APS-Z80

Inductive position sensor for precise position detection of the gripper jaws with analog output

7 APS-M15

Mechanical measuring system for precise position detection of the gripper jaw with analog output

8 MMS 22

Magnetic switch with straight cable outlet for monitoring a position

MMS 22-PI1

Magnetic switch with straight cable outlet for monitoring a freely programmable position

9 MMS 22-PI2

Magnetic switch with straight cable outlet for monitoring two freely programmable positions

10 MMS 22-PI1-HD

MMS 22-PI1 in robust design

MMS 22-PI2-HD

MMS 22-PI2 in robust design

11 MMS 22-SA

Magnetic switch with lateral cable outlet for monitoring a position

MMS 22-PI1-SA

Magnetic switch with side cable outlet for monitoring a freely programmable position

12 MMS-P

Magnetic switch with straight cable outlet for monitoring two freely programmable positions

13 MMS-A

Analog magnetic switch with straight cable outlet for measuring the gripper jaw position with analog output and teach function

Complementary products

14 CWS

Manual change system with integrated air feed-through for simple exchange of the handling components

15 TCU

Tolerance compensation unit for compensating small tolerances in the plane

16 SDV-P-E-P

Pressure maintenance valve for temporary force and position maintenance

17 AGE

Compensation unit for compensation of large tolerances along the X and Y axes

18 ASG

Adapter plate for combining various automation components in the modular system

19 CLM

Linear module with pneumatic drive and scope-free pre-loaded junction rollers

20 HUE

Sleeve for protection against dirt

21 SAD

Dustproof version, retrofit kit

Finger Accessories

22 UZB

The universal intermediate jaw allows fast tool-free and reliable plugging and shifting of top jaws at the gripper.

23 BSWS-AR

Adapter coupling of jaw quick-change system for fast, manual change of top jaws

24 BSWS-B

Locking mechanism of the jaw quick-change system for fast, manual exchange of top jaws

25 BSWS-A

Adapter coupling of the jaw quick-change system for adaptation to the customized finger

26 Customized fingers

27 BSWS-ABR

Finger blank made of aluminum with interface to the jaw quick-change system

BSWS-SBR

Finger blank made of steel with interface to the jaw quick-change system

28 BSWS-UR

Locking mechanism for the integration of the jaw quick-change system into customized fingers

29 ABR/SBR

Finger blanks made of steel or aluminum with standardized screw connection diagram

30 ZBA

Intermediate jaws for reorientation of the mounting surface

PGN-plus-P 80

Universal gripper



Gripping force O.D. gripping

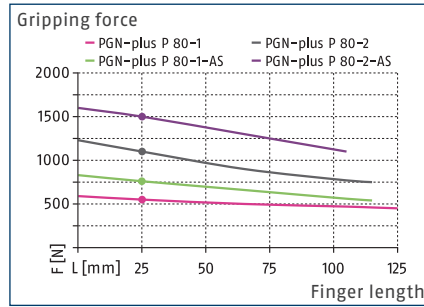

Gripping force I.D. gripping

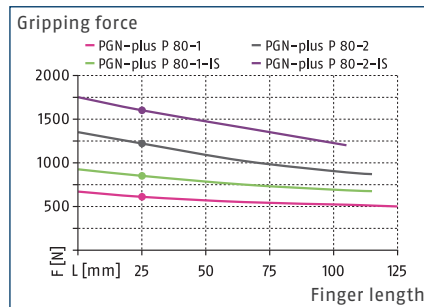

Dimensions and maximum loads

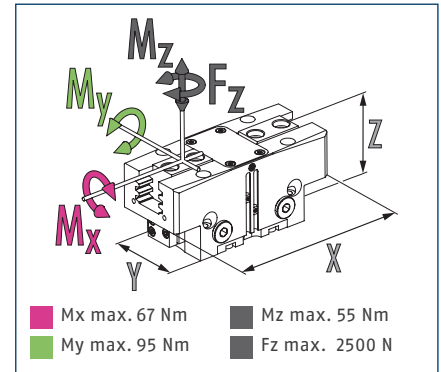

① The indicated moments and forces are static values, apply for each base jaw and may appear simultaneously. Loads may additionally occur to the moment produced by the gripping force itself.

Technical data

Description		PGN-plus-P 80-1	PGN-plus-P 80-2	PGN-plus-P 80-1-AS	PGN-plus-P 80-2-AS	PGN-plus-P 80-1-IS	PGN-plus-P 80-2-IS
ID		0318520	0318521	0318522	0318523	0318524	0318525
Stroke per jaw	[mm]	8	4	8	4	8	4
Closing/opening force	[N]	550/610	1100/1220	760/-	1500/-	-/850	-/1600
Min. spring force	[N]			210	400	240	380
Weight	[kg]	0.51	0.51	0.63	0.63	0.63	0.63
Recommended workpiece weight	[kg]	2.75	5.5	2.75	5.5	2.75	5.5
Fluid consumption double stroke	[cm ³]	29	29	44	44	52	52
Min./nom./max. operating pressure	[bar]	2.5/6/8	2.5/6/8	4/6/6.5	4/6/6.5	4/6/6.5	4/6/6.5
Min./max. air purge pressure	[bar]	0.5/1	0.5/1	0.5/1	0.5/1	0.5/1	0.5/1
Closing/opening time	[s]	0.035/0.035	0.035/0.035	0.03/0.05	0.03/0.05	0.05/0.03	0.05/0.03
Closing/opening time with spring	[s]			0.08	0.08	0.08	0.08
Max. permissible finger length	[mm]	125	115	115	105	115	105
Max. permissible mass per finger	[kg]	0.7	0.7	0.7	0.7	0.7	0.7
IP protection class		40	40	40	40	40	40
Min./max. ambient temperature	[°C]	5/90	5/90	5/90	5/90	5/90	5/90
Repeat accuracy	[mm]	0.01	0.01	0.01	0.01	0.01	0.01
Dimensions X x Y x Z	[mm]	96 x 42 x 49	96 x 42 x 49	96 x 42 x 67	96 x 42 x 67	96 x 42 x 67	96 x 42 x 67
Options and their characteristics							
Dustproof version		1317561	1317563	1317564	1317565	1317568	1317569
IP protection class		64	64	64	64	64	64
Weight	[kg]	0.58	0.58	0.7	0.7	0.7	0.7
Corrosion-protected version		38318520	38318521	38318522	38318523	38318524	38318525
High-temperature version		39318520	39318521	39318522	39318523	39318524	39318525
Min./max. ambient temperature	[°C]	5/130	5/130	5/130	5/130	5/130	5/130
Precision version		0318526	0318527	0318528	0318529		
H1 grease version		1353814	1360962	1353815	1475849	1353816	1475852
Dustproof/H1 grease version		1408195	1475847	1475848	1475850	1475851	1475853
Weight	[kg]	0.58	0.58	0.7	0.7	0.7	0.7
IP protection class		64	64	64	64	64	64

① It may take a few 100 gripping cycles until the full gripping force (as indicated in the data table) will be available.

Main view

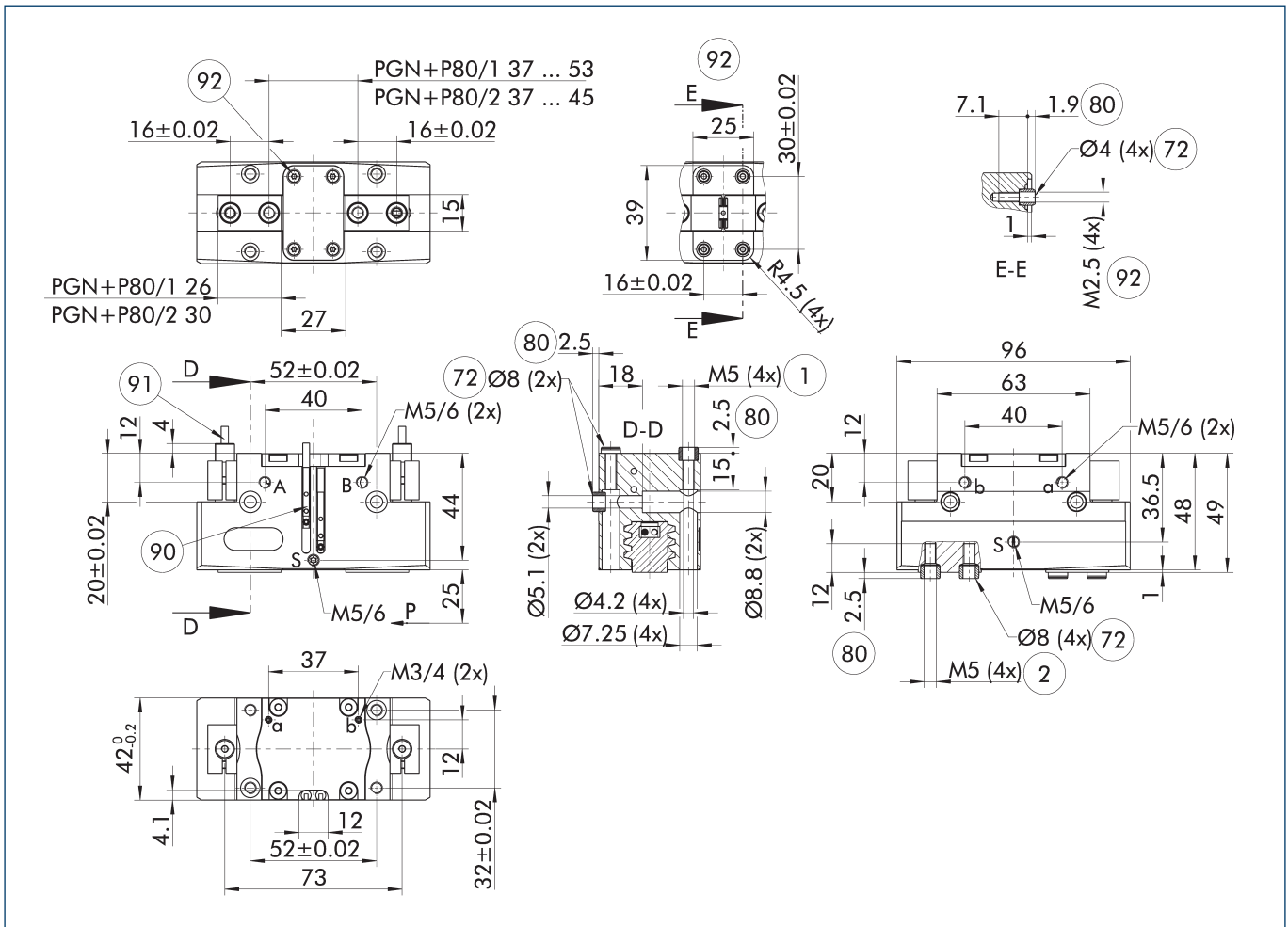

The drawing shows the gripper in the basic version with closed jaws, without dimensional consideration of the options described below.

① The SDV-P pressure maintenance valve can also be used for I.D. or O.D. gripping alternatively or in addition to the spring-loaded, mechanical gripping force maintenance device (see catalog section on accessories).

- A, a Main / direct connection, gripper opening
- B, b Main / direct connection, gripper closing
- S Air purge connection
- ① Gripper connection
- ② Finger connection
- 72 Fit for centering sleeves

- 80 Depth of the centering sleeve hole in the counter part
- 90 Sensor MMS 22..
- 91 Sensor IN ...
- 92 Screw connection with centering for customized mounting (these centering sleeves are not included in the scope of delivery)

PGN-plus-P 80

Universal gripper

Maximum permitted finger projection

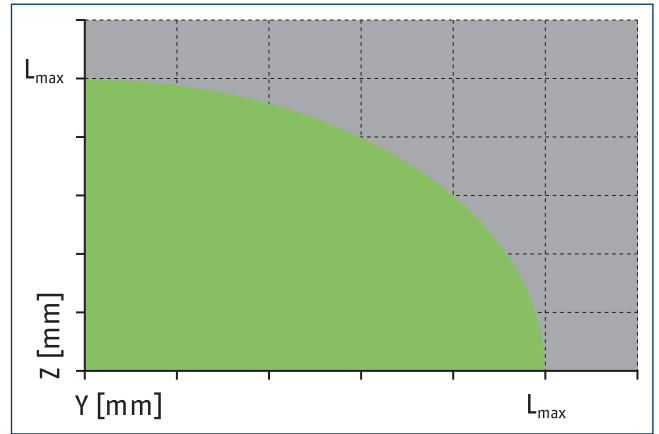
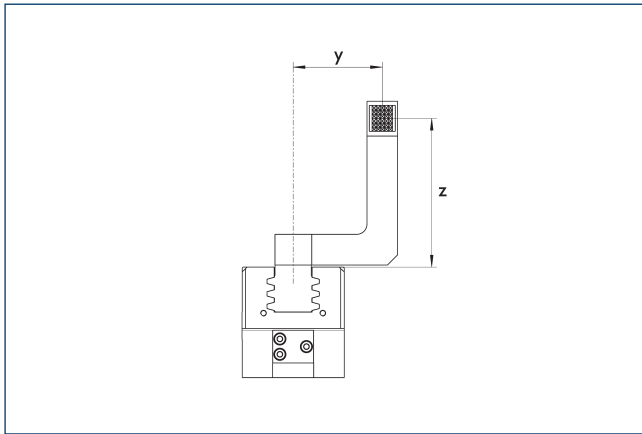

■ Permitted range

■ Inadmissible range

L_{max} is equivalent to the maximum permitted finger length, see the technical data table.

Hose-free direct connection M3

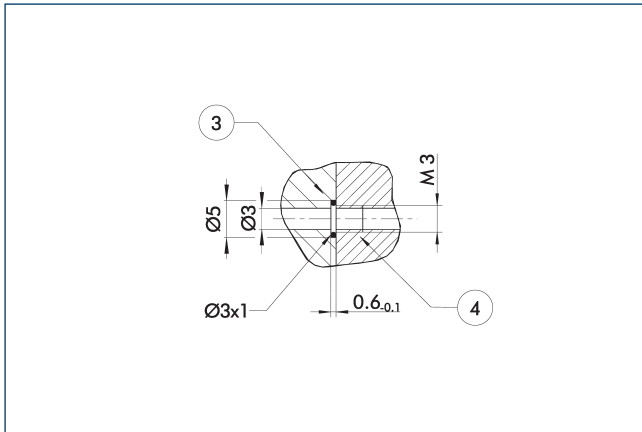

③ Adapter

④ Grippers

The direct connection is used for supplying compressed air without hoses. Instead, the pressure medium is fed through bore-holes in the mounting plate.

Gripping force maintenance device AS / IS

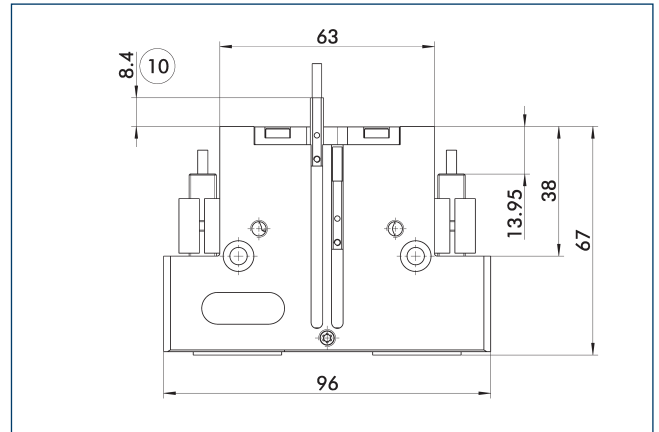

⑩ Projection applies only for AS version

The mechanical gripping force maintenance device ensures that a minimum clamping force will be applied even if there is a drop in pressure. This acts as closing force in the AS / S version, and as opening force in the IS version. Besides this, the gripping force maintenance device can be used to increase the gripping force or for single actuated gripping.

Dustproof version

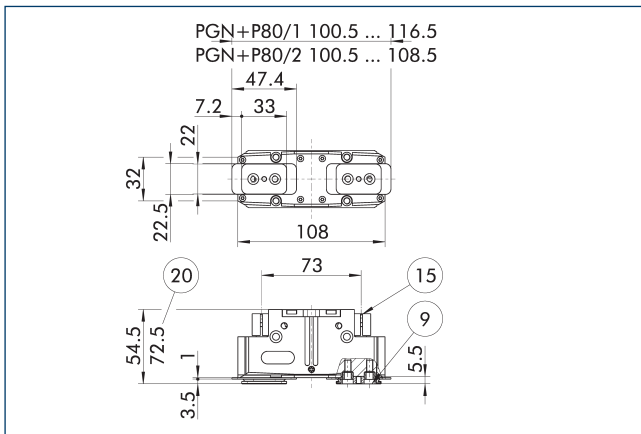

- ⑨ For mounting screw connection diagram, see basic version
- ⑮ Sealing bolt
- ⑳ For AS / IS version

The "dustproof" option increases the degree of protection against penetrating substances. The assembly diagram shifts by the height of the intermediate jaw. The finger length is still measured from the upper edge of the gripper housing.

Description	ID
Dust cover	
SAD PGN-plus-P 80	1347484

- ① The "dustproof" option can either be ordered as a pre-mounted gripper version or can be retrofitted to the gripper using the "SAD PGN-plus-P" retrofit kit.

Precision version

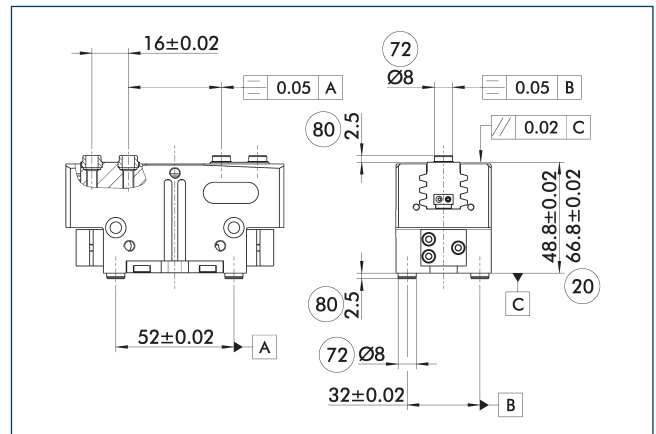

- ⑳ For AS / IS version
- ㉓ Fit for centering sleeves
- ㉔ Depth of the centering sleeve hole in the counter part

The indicated tolerances just refer to the variants of precision versions shown in the chart of technical specifications. All other variants of precision versions are available on request.

PGN-plus-P 80

Universal gripper

SDV-P pressure maintenance valve

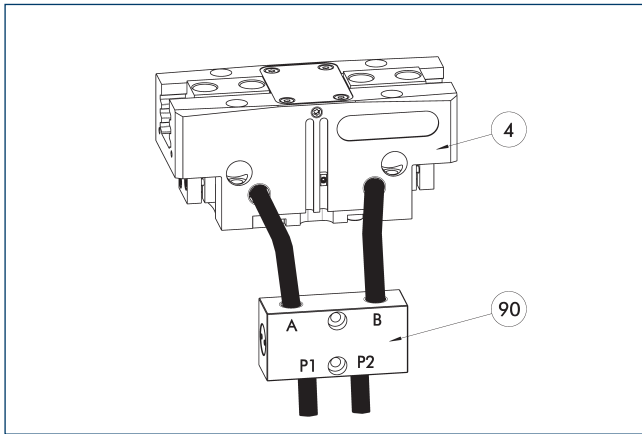

- ④ Grippers
- ⑨⑩ SDV-P pressure maintenance valve

The SDV-P pressure maintenance valve ensures in emergency STOP situations that the pressure in the piston chamber of pneumatic gripper, swivel, linear, and quick-change modules is temporarily maintained.

Description	ID	Recommended hose diameter [mm]
Pressure maintenance valve		
SDV-P 04	0403130	6
SDV-P 07	0403131	8
Pressure maintenance valve with air bleed screw		
SDV-P 04-E	0300120	6
SDV-P 07-E	0300121	8

- ① In order to achieve the specified closing and opening time for each gripper variant, the recommended hose diameter must be used. The direct allocation of the respective variant of the gripper for the respective SDV-P can be found at schunk.com.

SDV-P E-P pressure maintenance valve

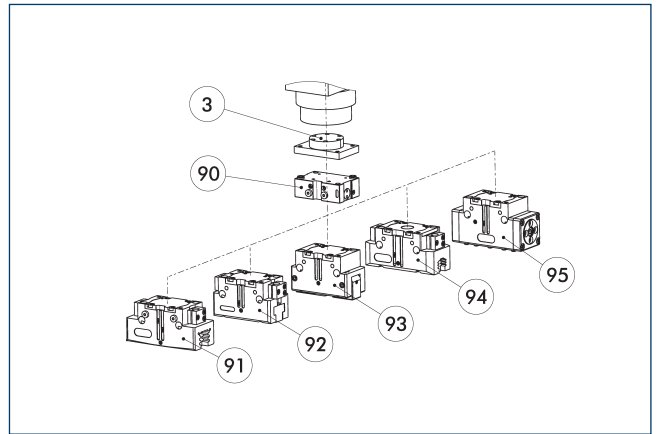

- ③ Adapter
- ⑨⑩ SDV-P E-P pressure maintenance valve
- ⑨① PGN-plus / PGN-plus-P 2-finger parallel gripper
- ⑨② JGP 2-finger parallel grippers
- ⑨③ 2-finger angular gripper PWG-plus
- ⑨④ 2-finger parallel gripper PGB
- ⑨⑤ Sealed DPG-plus gripper

The SDV-P E-P pressure maintenance valves ensure that the pressure in the piston chamber is maintained temporarily during an emergency stop. SDV-P E-P can be directly connected to the listed grippers without the need for additional pneumatic hoses.

Description	ID	
Pressure maintenance valve		
SDV-P 80-E-P	0300125	

Protective cover HUE PGN-plus 80

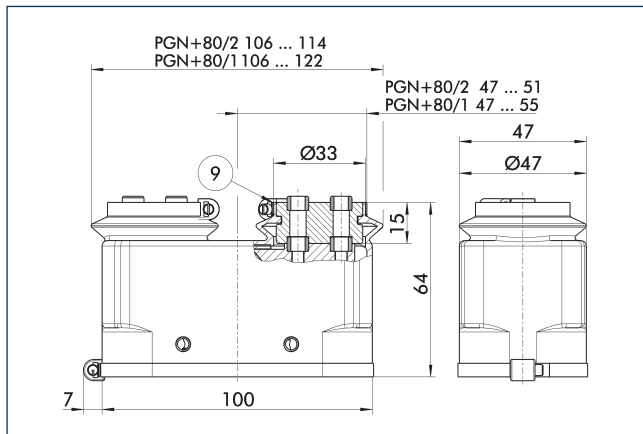

⑨ For mounting screw connection diagram, see basic version

The HUE protective cover fully protects the gripper against external influences. The cover is suitable for applications of up to IP65 if an additional sealing of the cover bottom is provided. For detailed information, please see the HUE series. The connection diagram shifts by the height of the intermediate jaw.

Description	ID	IP protection class
Protection cover		
HUE PGN-plus 80	0371481	65

ⓘ The HUE protective cover is not suitable for use on grippers with gripping force maintenance. An inductive monitoring of the gripper in connection with the HUE protective cover is not possible. SCHUNK recommends the use of magnetic sensors that are approved for the respective gripper variant.

BSWS jaw quick-change jaw systems

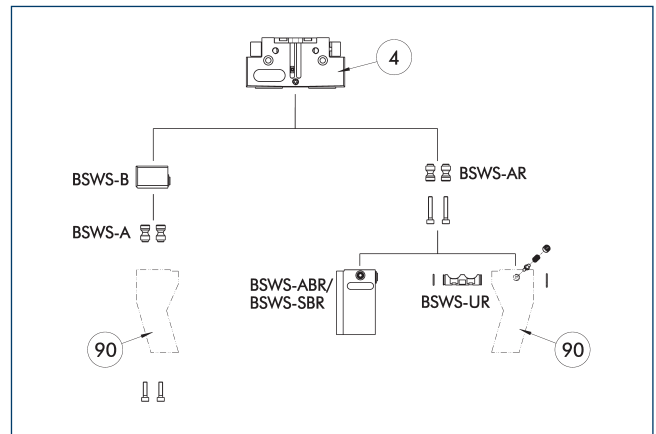

④ Grippers

⑨ Customized gripper fingers

There are various jaw quick-change systems available for the gripper. For detailed information, please refer to the corresponding product.

Description	ID	Scope of delivery
Jaw quick-change system adapter pin		
BSWS-A 80	0303024	2
BSWS-AR 80	0300093	2
Quick-change jaw system base		
BSWS-B 80	0303025	1
Jaw quick-change system finger blank		
BSWS-ABR-PGZN-plus 80	0300073	1
BSWS-SBR-PGZN-plus 80	0300083	1
Jaw quick-change system locking mechanism		
BSWS-UR 80	0302992	1

ⓘ Only systems that are listed in the table, can be used.

Fields of application

Series	Size	Variant	Suitability
PGN-plus-P	80	-1 (6 bar)	■■■■■
PGN-plus-P	80	-1-AS / -1-IS (6 bar)	■■■■■
PGN-plus-P	80	-2 (6 bar)	■■■■■
PGN-plus-P	80	-2-AS / -2-IS (6 bar)	■■■■■
Legend			
■■■■■	Can be combined without restrictions		
■■■□□	Use with restrictions (see loading limits)		
□□□□	cannot be combined		

The load limits for describing the application limits can be found in the catalog chapter of the corresponding accessories.

If the operating pressure is higher than 6 bar, suitability for use above the application limits must be checked.

PGN-plus-P 80

Universal gripper

Jaw quick-change system BSWs-M

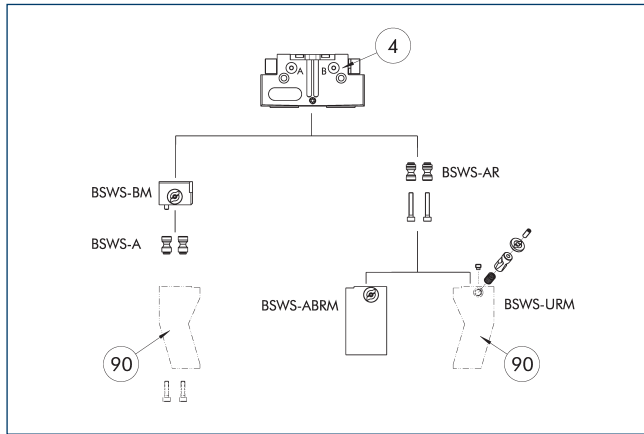

- ④ Grippers
- ⑨⑩ Customized gripper fingers

There are various jaw quick-change systems available for the gripper. For detailed information, please refer to the corresponding product.

Description	ID	Scope of delivery
Jaw quick-change system adapter pin		
BSWS-A 80	0303024	2
BSWS-AR 80	0300093	2
Quick-change jaw system base		
BSWS-BM 80	1313901	1
Jaw quick-change system finger blank		
BSWS-ABRM-PGZN-plus 80	1420852	1
Jaw quick-change system locking mechanism		
BSWS-URM 80	1398402	1

① Only systems that are listed in the table, can be used.

Fields of application

Series	Size	Variant	Suitability
PGN-plus-P	80	-1 (6 bar)	■■■■
PGN-plus-P	80	-1-AS / -1-IS (6 bar)	■■■■
PGN-plus-P	80	-2 (6 bar)	■■■■
PGN-plus-P	80	-2-AS / -2-IS (6 bar)	■■■■
Legend			
■■■■	Can be combined without restrictions		
■■□□	Use with restrictions (see loading limits)		
□□□□	cannot be combined		

The load limits for describing the application limits can be found in the catalog chapter of the corresponding accessories. If the operating pressure is higher than 6 bar, suitability for use above the application limits must be checked.

ZBA-L-plus 80 intermediate jaws

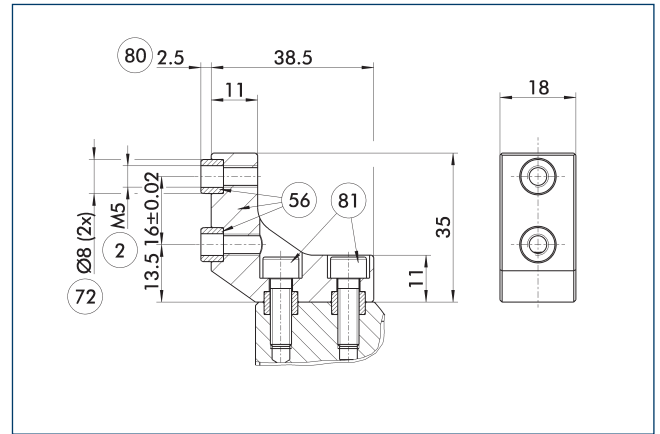

- ② Finger connection
- ⑤⑥ Included in the scope of delivery
- ⑦② Fit for centering sleeves
- ⑧⑩ Depth of the centering sleeve hole in the counter part
- ⑧① Not included in the scope of delivery

The optional ZBA-L-plus intermediate jaws allow the screw connection diagram of the top jaws to be rotated by 90°. This makes it easier to design and produce top jaws (particularly for long versions) because no deep through-bores are required.

Description	ID	Material	Finger interface	Scope of delivery
Intermediate jaw				
ZBA-L-plus 80	0311732	Aluminum	PGN-plus 80	1

UZH 80 universal intermediate jaw

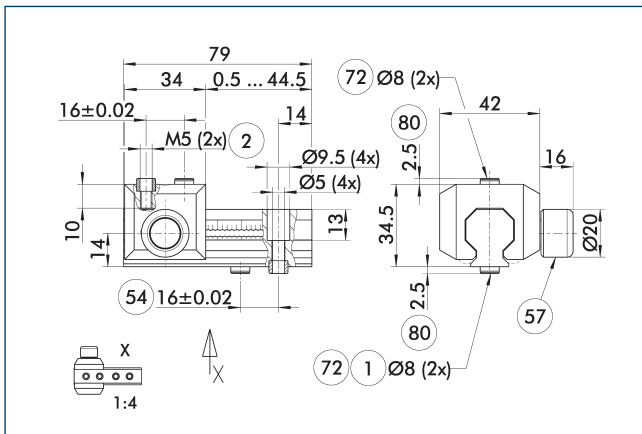

- ① Gripper connection
- ② Finger connection
- ⑤④ Optional right or left connection
- ⑤⑦ Locking
- ⑦② Fit for centering sleeves
- ⑧① Depth of the centering sleeve hole in the counter part

The drawing shows the UZH universal intermediate jaw. The fully removable UZH-S slide (can also be ordered separately) allows for a quick jaw change.

Description	ID	Grid dimension
		[mm]
Universal intermediate jaw		
UZH 80	0300043	2
Finger blank		
ABR-PGZN-plus 80	0300011	
SBR-PGZN-plus 80	0300021	
Slide for universal intermediate jaw		
UZH-S 80	5518271	2

Fields of application

Series	Size	Variant	Suitability
PGN-plus-P	80	-1 (6 bar)	■■■■
PGN-plus-P	80	-1-AS / -1-IS (6 bar)	■■□□
PGN-plus-P	80	-2 (6 bar)	■■□□
PGN-plus-P	80	-2-AS / -2-IS (6 bar)	□□□□
Legend			
■■■■	Can be combined without restrictions		
■■□□	Use with restrictions (see loading limits)		
□□□□	cannot be combined		

The load limits for describing the application limits can be found in the catalog chapter of the corresponding accessories. If the operating pressure is higher than 6 bar, suitability for use above the application limits must be checked.

Finger blanks ABR- / SBR-PGZN-plus 80

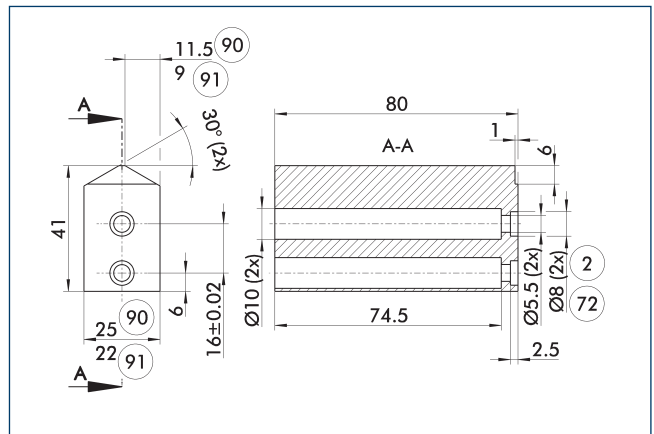

- ② Finger connection
- ⑦② Fit for centering sleeves
- ⑨① ABR-PGZN-plus
- ⑨② SBR-PGZN-plus

The drawing shows the finger blank which can be reworked by the customer.

Description	ID	Material	Scope of delivery
Finger blank			
ABR-PGZN-plus 80	0300011	Aluminum	1
SBR-PGZN-plus 80	0300021	Steel	1

PGN-plus-P 80

Universal gripper

Tolerance compensation unit TCU

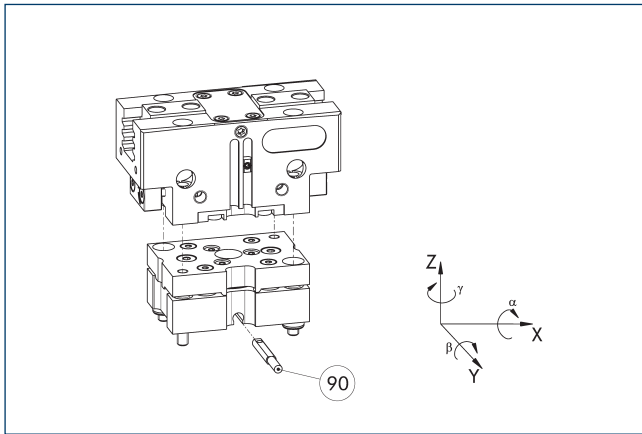

90 Monitoring of locking

Grippers can be directly mounted without an adapter plate. Tolerance compensation unit and gripper have an identical screw connection diagram. Therefore the tolerance compensation units can be assembled later. Please consider the additional assembly height of the tolerance compensation unit. For details please refer to our catalog robot accessories.

Description	ID	Locking	Deflection	Often combined
Compensation unit				
TCU-P-080-3-MV	0324792	yes	$\pm 1^\circ / \pm 1,5^\circ / \pm 2^\circ$	●
TCU-P-080-3-OV	0324793	no	$\pm 1^\circ / \pm 1,5^\circ / \pm 2^\circ$	

Compensation unit AGE-F

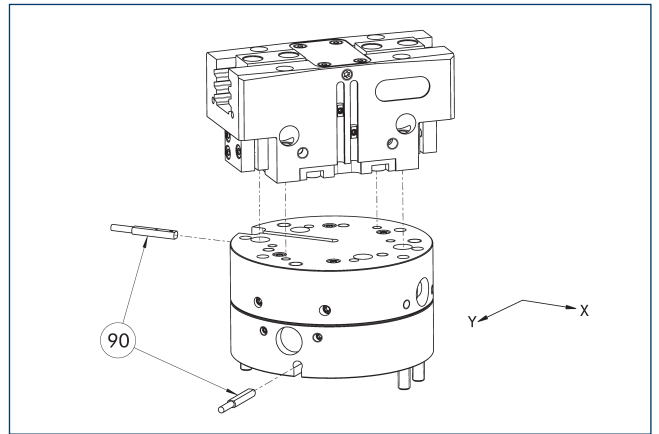

90 Monitoring

The unit has direct connection possibilities for different grippers of the PGN-plus, PGN-plus-P and PZN-plus series. For more detailed information, please refer to the main view.

Description	ID	Compensation XY [mm]	Reset force [N]	Often combined
Compensation unit				
AGE-F-XY-063-1	0324940	± 4	12	
AGE-F-XY-063-2	0324941	± 4	16	
AGE-F-XY-063-3	0324942	± 4	20	●

① Due to the interfering contour, monitoring of the gripper is not possible.

Adapter plate PGN-plus 80

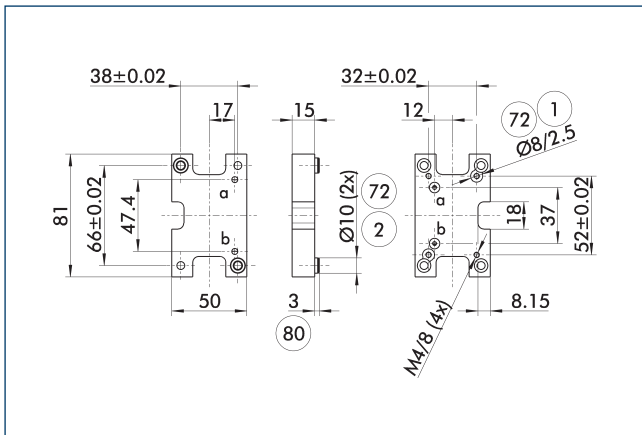

- ① Robot-side connection
- ② Tool-side connection
- 72 Fit for centering sleeves
- 80 Depth of the centering sleeve hole in the counter part

The adapter plate has integrated air feed-throughs in order to be able to use the hose-free direct connection of the appropriate gripper.

Description	ID
Tool side	
A-CWA-100-080-P	0305804

Compact change system for grippers

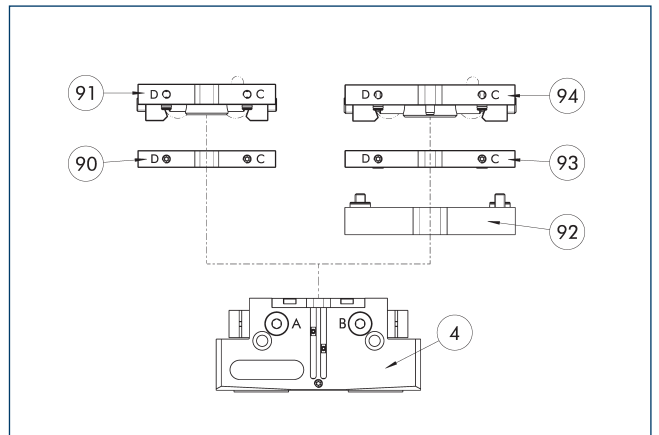

- ④ Grippers
- 90 CWA compact change adapter
- 91 CWK compact change master
- 92 A-CWA adapter plate
- 93 CWA compact change adapter
- 94 CWK compact change master

Grippers can be directly mounted without an adapter plate. For details see our catalog Gripping or Robot Accessories.

Description	ID
Tool side	
A-CWA-100-080-P	0305804
CWA compact change adapter	
CWA-080-P	0305781
CWK compact change master	
CWK-080-P	0305780

Attachment valves

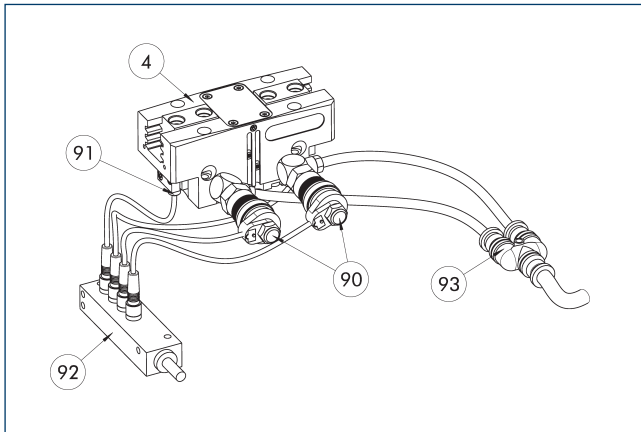

- ④ Grippers
- ⑨② Sensor distributor
- ⑨① Micro valves
- ⑨③ Y distributor
- ⑨① Sensor

The set of attachment valves reduces the compressed air consumption as there is no need to ventilate or bleed the supply lines. This can also reduce cycle time. The hose-free direct assembly of the micro valves reduces the hosing effort for the gripper. To further simplify electrical connection of the valves and sensors, their signals can be bundled via an optional distributor.

Description	ID	Often combined
Attachment valve		
ABV-MV25-M5	0303326	
ABV-MV25-M5-V2-M8	0303392	
ABV-MV25-M5-V4-M8	0303362	●
ABV-MV25-M5-V8-M8	0303363	

① A set of attachment valves ABV is required per actuator. The ABV set contains two 3/2 micro valves, an Y-distributor for compressed air supply and optionally a sensor distributor with two, four or eight inputs or outputs. Sensors for monitoring the gripper need to be ordered separately. Pneumatic hoses are not included in the scope of delivery.

Modular Assembly Automation

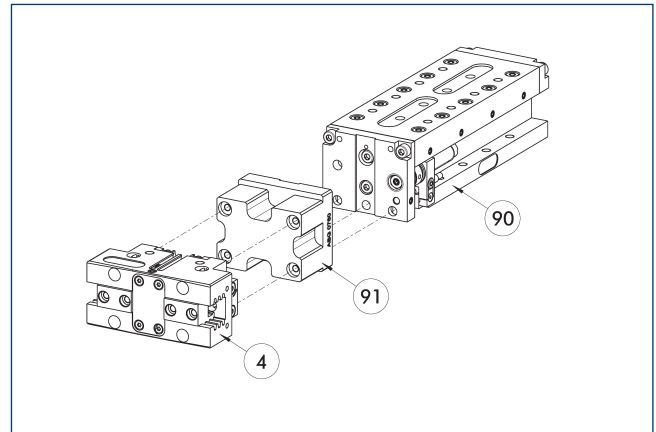

- ④ Grippers
- ⑨① ASG adapter plate
- ⑨① CLM/KLM/LM/ELP/ELM/ELS/HLM linear modules

Grippers and linear modules can be combined with standard adapter plates from the modular assembly system. For more information see our main catalog "Modular Assembly Automation".

PGN-plus-P 80

Universal gripper

Inductive Proximity Switches

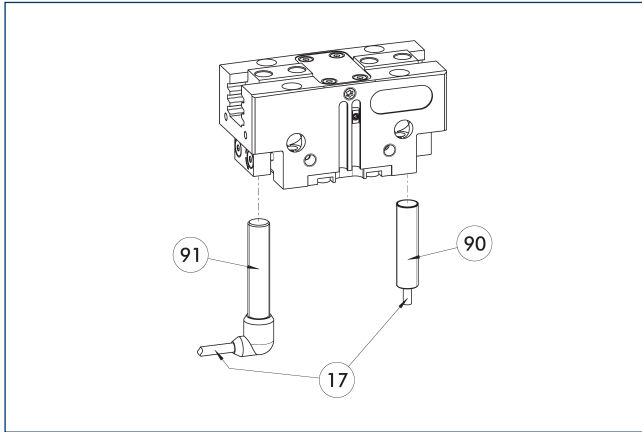

- 17 Cable outlet
- 90 Sensor IN ...
- 91 Sensor IN..-SA

Directly mounted end position monitoring.

Description	ID	Often combined
Inductive proximity switches		
IN 80-S-M12	0301578	
IN 80-S-M8	0301478	●
INK 80-S	0301550	
Inductive proximity switch with lateral cable outlet		
IN 80-S-M12-SA	0301587	
IN 80-S-M8-SA	0301483	●
INK 80-S-SA	0301566	
Connection cables		
KA BG08-L 3P-0300-PNP	0301622	●
KA BG08-L 3P-0500-PNP	0301623	
KA BG12-L 3P-0500-PNP	30016369	
KA BW08-L 3P-0300-PNP	0301594	
KA BW08-L 3P-0500-PNP	0301502	
KA BW12-L 3P-0300-PNP	0301503	
KA BW12-L 3P-0500-PNP	0301507	
clip for plug/socket		
CLI-M12	0301464	
CLI-M8	0301463	
Cable extension		
KV BG12-SG12 3P-0030-PNP	0301999	
KV BG12-SG12 3P-0060-PNP	0301998	
KV BW08-SG08 3P-0030-PNP	0301495	
KV BW08-SG08 3P-0100-PNP	0301496	
KV BW08-SG08 3P-0200-PNP	0301497	●
KV BW12-SG12 3P-0030-PNP	0301595	
KV BW12-SG12 3P-0100-PNP	0301596	
KV BW12-SG12 3P-0200-PNP	0301597	
Sensor distributor		
V2-M12	0301776	●
V2-M8	0301775	●
V4-M8	0301746	
V8-M8	0301751	

- ① Two sensors are required per unit for monitoring two positions. On option, extension cables and sensor distributors are available. Additional product variants of the sensor, and further information and technical data can be found in the catalog chapter sensor system.

Flexible position sensor

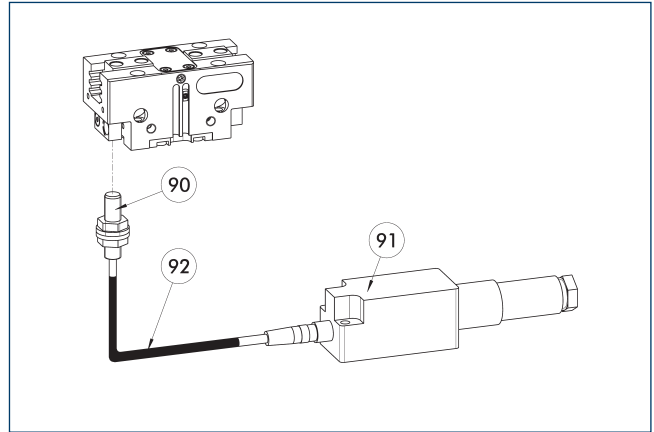

- 90 FPS-S sensor
- 91 FPS-F5 evaluation electronic
- 92 Cable extension

Flexible position monitoring of up to five positions.

Description	ID	
Attachment kit for FPS		
AS-FPS-PGN-plus-P 64/80	1363890	
Sensor		
FPS-S M8	0301704	
Evaluation electronics		
FPS-F5	0301805	
Cable extension		
KV BG08-SG08 3P-0050	0301598	
KV BG08-SG08 3P-0100	0301599	

- ① When using an FPS system, an FPS sensor (FPS-S) as well as an electronic processor (FPS-F5 / F5 T) are required for each gripper as well as a mounting kit (AS), if listed. Cable extensions (KV) are optionally available – see catalog chapter "Accessories."

Electronic magnetic switch MMS

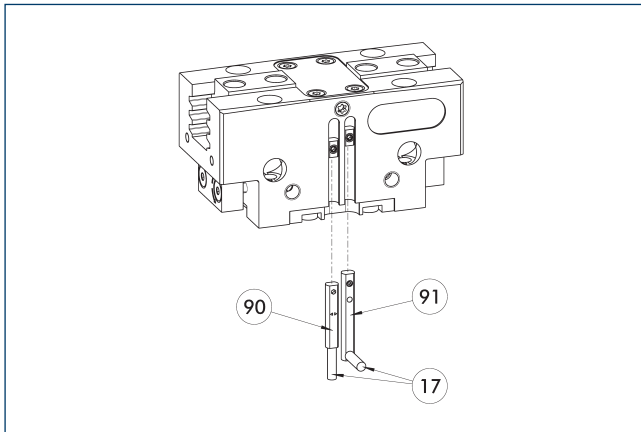

- ①⑦ Cable outlet
- ①⑨ Sensor MMS 22 ..-PI1-...-SA
- ①⑩ Sensor MMS 22 PI1-...

End position monitoring for mounting in the C-slot.

Description	ID	Often combined
Electronic magnetic switch		
MMS 22-S-M8-PNP	0301032	●
MMSK 22-S-PNP	0301034	
Electronic magnetic switches with lateral cable outlet		
MMS 22-S-M8-PNP-SA	0301042	●
MMSK 22-S-PNP-SA	0301044	
Connection cables		
KA BG08-L 3P-0300-PNP	0301622	●
KA BG08-L 3P-0500-PNP	0301623	
KA BW08-L 3P-0300-PNP	0301594	
KA BW08-L 3P-0500-PNP	0301502	
clip for plug/socket		
CLI-M8	0301463	
Cable extension		
KV BW08-SG08 3P-0030-PNP	0301495	
KV BW08-SG08 3P-0100-PNP	0301496	
KV BW08-SG08 3P-0200-PNP	0301497	●
Sensor distributor		
V2-M8	0301775	●
V4-M8	0301746	
V8-M8	0301751	

- ① Two sensors are required per unit for monitoring two positions. On option, extension cables and sensor distributors are available. Additional product variants of the sensor, and further information and technical data can be found in the catalog chapter sensor system.

Programmable magnetic switch MMS 22-PI1

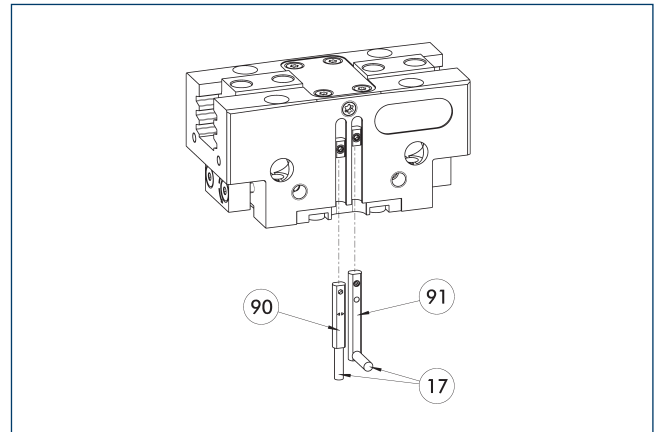

- ①⑦ Cable outlet
- ①⑨ Sensor MMS 22 ..-PI1-...-SA
- ①⑩ Sensor MMS 22 PI1-...

Position monitoring with one programmable position per sensor and integrated electronic system in the sensor. Can be programmed using MT magnetic teaching tool (included in the scope of delivery) or ST plug teaching tool (optional). End position monitoring for mounting in the C-slot. If the ST plug teaching tools are listed in the table provided, teaching is only possible with the ST teaching tools.

Description	ID	Often combined
Programmable magnetic switch		
MMS 22-PI1-S-M8-PNP	0301160	●
MMSK 22-PI1-S-PNP	0301162	
Programmable magnetic switch with lateral cable outlet		
MMS 22-PI1-S-M8-PNP-SA	0301166	●
MMSK 22-PI1-S-PNP-SA	0301168	
Programmable magnetic switch with stainless steel housing		
MMS 22-PI1-S-M8-PNP-HD	0301110	●
MMSK 22-PI1-S-PNP-HD	0301112	

- ① Two sensors are required per unit for monitoring two positions. On option, extension cables and sensor distributors are available. Additional product variants of the sensor, and further information and technical data can be found in the catalog chapter sensor system.

PGN-plus-P 80

Universal gripper

Programmable magnetic switch MMS 22-PI2

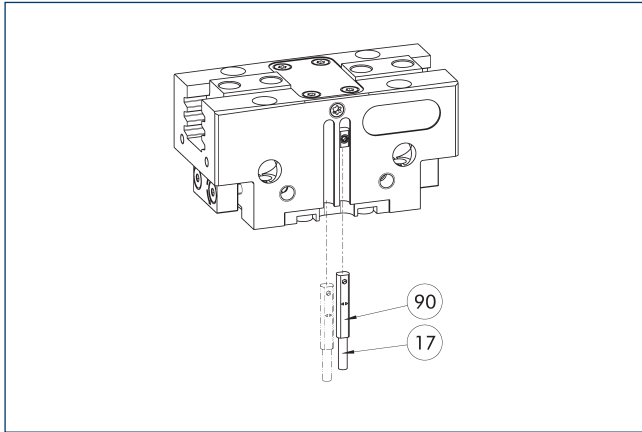

⑰ Cable outlet

⑨⑩ MMS 22...-PI2-... sensor

Position monitoring with two programmable positions per sensor and electronics built into the sensor. Can be programmed using MT magnetic teaching tool (included in the scope of delivery) or ST plug teaching tool (optional). End position monitoring for mounting in the C-slot. If the ST plug teaching tools are listed in the table provided, teaching is only possible with the ST teaching tools.

Description	ID	Often combined
Programmable magnetic switch		
MMS 22-PI2-S-M8-PNP	0301180	●
MMSK 22-PI2-S-PNP	0301182	
Programmable magnetic switch with lateral cable outlet		
MMS 22-PI2-S-M8-PNP-SA	0301186	●
MMSK 22-PI2-S-PNP-SA	0301188	
Programmable magnetic switch with stainless steel housing		
MMS 22-PI2-S-M8-PNP-HD	0301130	●
MMSK 22-PI2-S-PNP-HD	0301132	

① One sensor is required per unit for monitoring two positions. Extension cables and sensor distributors are optionally available. Additional product variants of the sensor, and further information and technical data can be found in the catalog chapter sensor systems.

MMS-P programmable magnetic switch

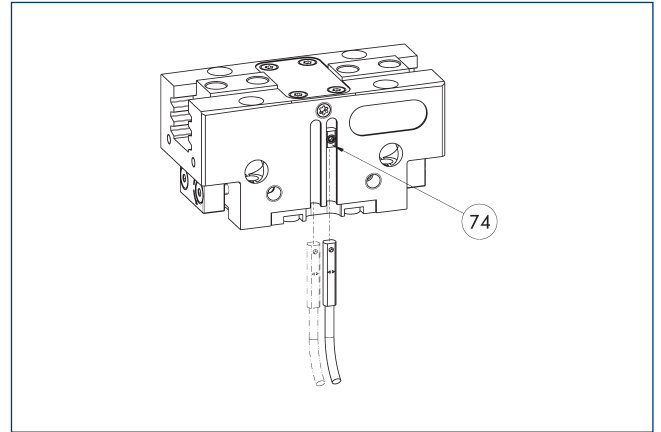

⑦④ Limit stop for sensor

Position monitoring with two programmable positions per sensor. End position monitoring for mounting in the C-slot.

Description	ID	Often combined
Programmable magnetic switch		
MMSK-P 22-S-PNP	0301371	
MMS-P 22-S-M8-PNP	0301370	●
Connection cables		
KA GLN0804-LK-00500-A	0307767	●
KA GLN0804-LK-01000-A	0307768	
KA WLN0804-LK-00500-A	0307765	
KA WLN0804-LK-01000-A	0307766	
clip for plug/socket		
CLI-M8	0301463	
Sensor distributor		
V2-M8-4P-2XM8-3P	0301380	

① One sensor is required per unit for monitoring two positions. Extension cables and sensor distributors are optionally available. Additional product variants of the sensor, and further information and technical data can be found in the catalog chapter sensor systems.

MMS-A analog position sensor

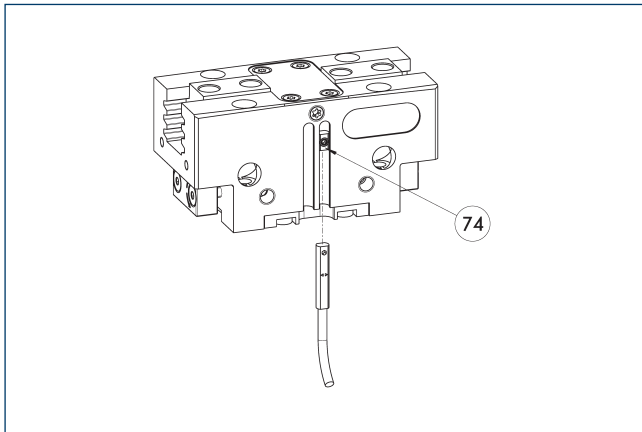

74 Limit stop for sensor

No-contact measuring, analog multi-position monitoring for any number of positions.

Description	ID
Analog position sensor	
MMS 22-A-10V-M08	0315825
MMS 22-A-10V-M12	0315828

① One sensor is required for each gripper. No additional mounting kit is required – the gripper is equipped for use of the sensor by default. Further information and technical data can be found in the catalog chapter sensor systems.

Flexible position sensor with MMS-A

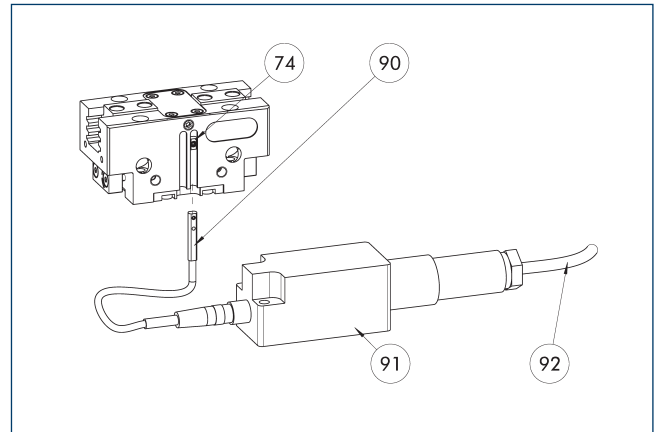

74 Limit stop for sensor

90 MMS 22-A-... sensor

91 FPS-F5 evaluation electronic

92 Connection cables

Flexible position monitoring of up to five positions.

Description	ID
Analog position sensor	
MMS 22-A-05V-M08	0315805
Evaluation electronics	
FPS-F5	0301805
Connection cables	
KA BG16-L 12P-1000	0301801

① When using an FPS system, one MMS 22-A-05V and one electronic processor (FPS-F5) are required per each gripper, as well as a mounting kit (AS), if listed. Cable extensions (KV) are optionally available – see catalog chapter "Accessories."

PGN-plus-P 80

Universal gripper

Programmable magnetic switch MMS-IO-Link

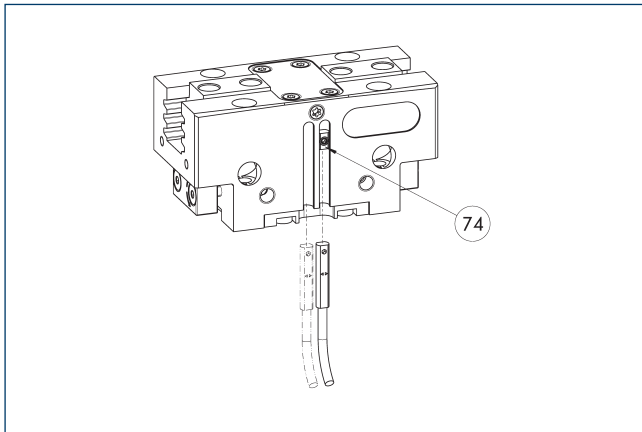

74 Limit stop for sensor

Sensor for multi-position monitoring through detection of the complete gripper stroke. The sensor is mounted directly in the C-slot of the gripper. Sensor programming on the gripper takes place via the IO-Link interface or the MT magnetic teach tool (included in scope of delivery). An IO-Link master is required for operation.

Description	ID	
Programmable magnetic switch		
MMS 22-IOL-M08	0315830	
MMS 22-IOL-M12	0315835	

① One sensor is required for each gripper. No additional mounting kit is required – the gripper is equipped for use of the sensor by default. Further information and technical data can be found in the catalog chapter sensor systems.

APS-Z80 analog position sensor

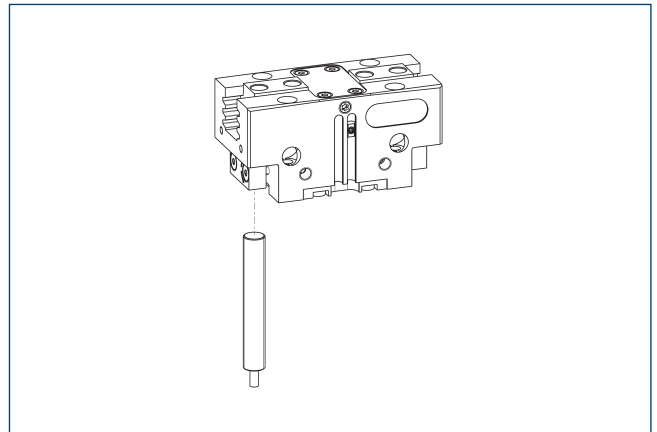

No-contact measuring, analog multi-position monitoring for any number of positions.

Description	ID	Often combined
Mounting kit for APS-Z80		
AS-APS-Z80-PGN-plus-P 80-1	1366209	
AS-APS-Z80-PGN-plus-P 80-2	1366215	
Analog position sensor		
APS-Z80-K	0302072	
APS-Z80-M8	0302070	●

① When using an APS system, one mounting kit (AS-APS-Z80) and one APS-Z80 sensor is required per gripper. The resolution of the sensor can be lower in the peripheral areas of the gripper. You can find further information on the product in the operating manual.

APS-M1 analog position sensor

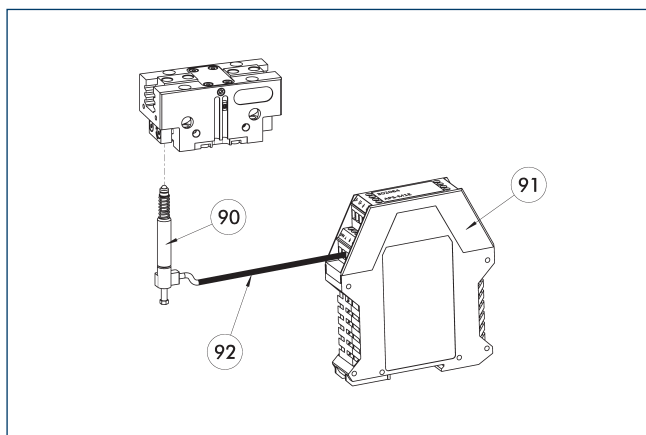

- ⑨⑩ APS-M1S sensor
- ⑨① APS-M1E electronic processor
- ⑨② APS-K extension cable

Analog multi position monitoring for any desired positions

Description	ID	
Mounting kit for APS-M1		
AS-APS-M1-PGN-plus-P 80-1	1363725	
AS-APS-M1-PGN-plus-P 80-2	1363731	
Analog position sensor		
APS-M1S	0302062	
Connection cables		
APS-K0200	0302066	
APS-K0700	0302068	
Evaluation electronics		
APS-M1E	0302064	

- ① When using an APS system, for each gripper an attachment kit (AS-APS-M1), an APS-M1S sensor (incl. 3 m cable) as well as an electronics (APS-M1e) are required. An extension cable (APS-K) can be connected between the sensor and the electronics as an option. The max. cable length between the sensor and the electronics is 10 m, between the electronics and their control unit (PLC) it is max. 1 m.



SCHUNK GmbH & Co. KG
Spann- und Greiftechnik

Bahnhofstr. 106 - 134
D-74348 Lauffen/Neckar
Tel. +49-7133-103-0
Fax +49-7133-103-2399
info@de.schunk.com
schunk.com

Folgen Sie uns | *Follow us*

