

Superior Clamping and Gripping



Product Information

Plug & Work Portfolio Universal Robots – Changing

Plug & Work Portfolio Universal Robots

Plug & Work Portfolio Universal Robots

Modular. Flexible. Easy.

Plug & Work Portfolio Universal Robots

The Plug & Work portfolio consists of electrically and pneumatically actuated grippers, quick-change modules and force/moment sensors that are specifically adapted to robot arms from Universal Robots.

Field of application

The components can be used in clean and slightly dirty environments.

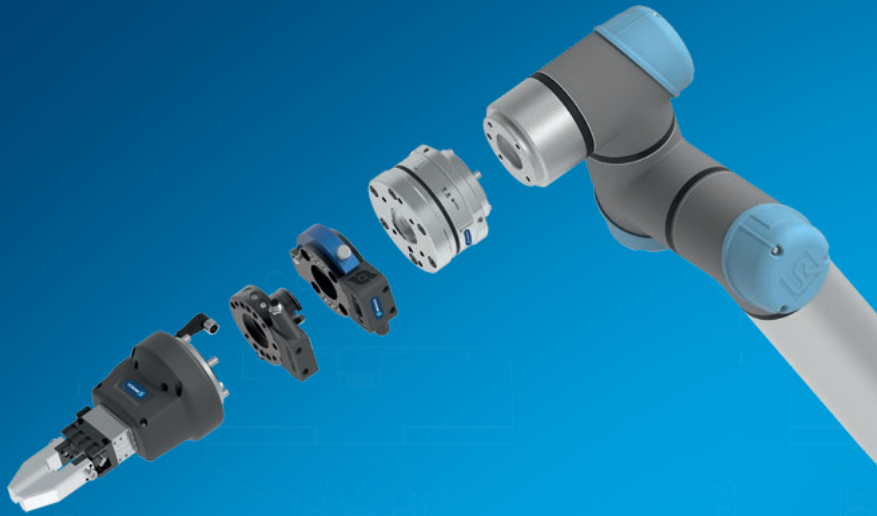

Advantages – Your benefits

Comprehensive portfolio consisting of various components and grippers for different applications for fast and easy entry into automation

Plug & Work with the interfaces suitable for all robots from Universal Robots

Software modules for robot control are included in the scope of delivery for fast and easy commissioning

Pre-assembled gripping unit with robot interface therefore no mounting kits or external valves required

Certified SCHUNK Co-act grippers For quick and easy entry into the world of collaborative applications

Electric grippers with a long adjustable stroke and force range for flexible workpiece handling

Pneumatic grippers For a high power density and simple integration

m

Weight
0.14 .. 2.63 kg

F

Gripping force
40 .. 870 N

S

Stroke per jaw
3 .. 42.5 mm

m

Workpiece weight
0.2 .. 11 kg

Functional description

All the Plug & Work components are prepared for mechanical and electrical direct connection to Universal Robots sizes 3, 5, 10, and 16. Depending on requirements, various grippers and end-of-arm components can be selected.

The pneumatic gripping units are additionally equipped with micro valves meaning no external valves are required.

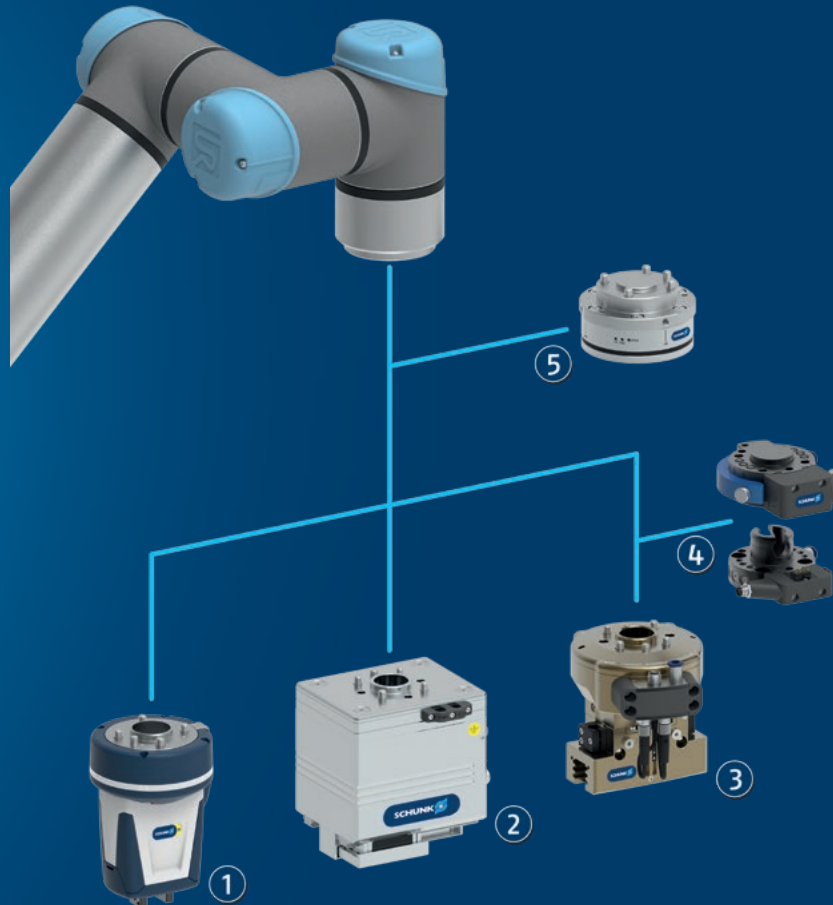

- ① **Co-act Gripper**
for implementing collaborative applications
- ② **Electric gripper**
for flexible handling of workpieces
- ③ **Pneumatic grippers**
For conventional, robust handling of workpieces

- ④ **Change systems**
for manual exchange of different grippers and actuators
- ⑤ **Force/torque sensor**
for measuring and processing of forces and torques on the robot arm

Plug & Work Portfolio Universal Robots

Plug & Work Portfolio Universal Robots

General notes about the series

Scope of delivery: Components for direct connection to robots from Universal Robots, assembly and operating manual with declaration of incorporation, USB stick with URcap

Gripping force: is the arithmetic sum of the individual force applied to each jaw at distance P (see illustration).

Finger length: The maximum permissible finger length applies until the nominal operating pressure is achieved. With higher pressures, the finger length must be reduced proportionally to the nominal operating pressure.

Repeat accuracy: is defined as a distribution of the end Position for 100 consecutive strokes.

Actuation: Control via digital I/O

Workpiece weight: is calculated for force-fit gripping with a coefficient of static friction of 0.1 and a safety factor of 2 against workpiece slippage at acceleration due to gravity g . For form-fit or capture gripping, there are significantly higher permissible workpiece weights.

Closing and opening times: are purely the times that the base jaws or fingers are in motion. Valve switching times, hose fill times, or PLC reaction times are not included, and are to be considered when cycle times are calculated.

Application example

Pneumatic gripping units for Universal Robots for flexible handling of various workpieces. By combining change system and gripping unit, the gripper can be exchanged to suit the workpiece.

- 1 Manual change system SHS
- 2 2-finger parallel gripper PGN-plus-P
- 3 3-finger centric gripper PZN-plus

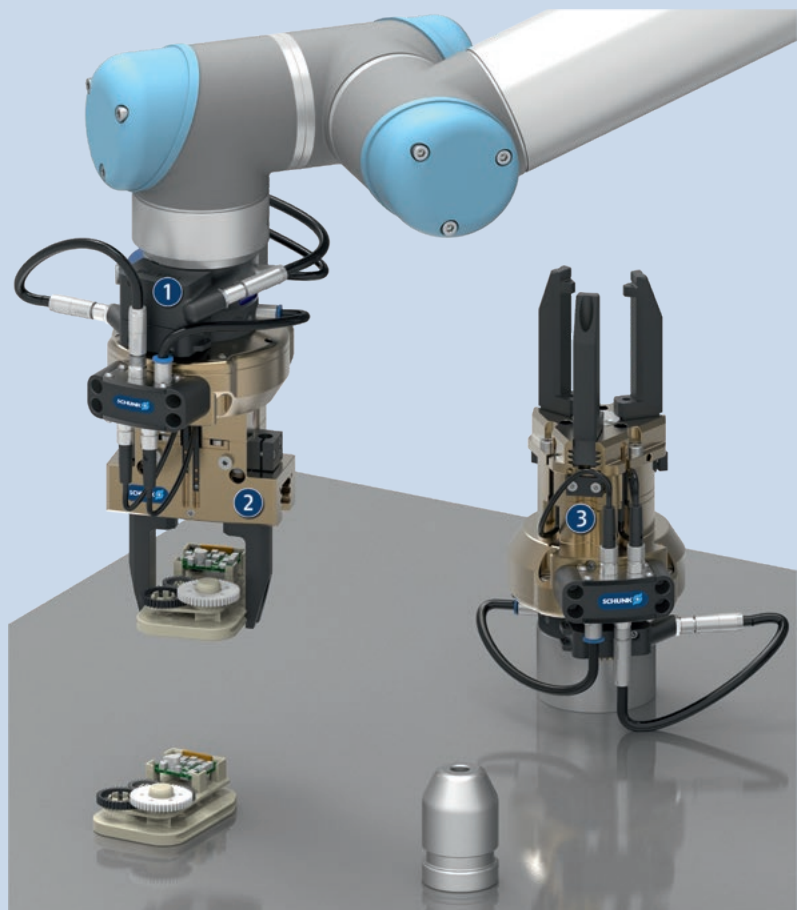

SCHUNK offers more ...

The following components make the product even more productive – the suitable addition for the highest functionality, flexibility, reliability, and controlled production.



Universal intermediate jaw



Jaw quick-change system



Finger blank



Finger blank with jaw quick-change system



Attachment fingers

① For more information on these products can be found on the following product pages or at schunk.com.

Options and special information

Further technical data and accessories: The products from the Plug & Work portfolio represent a selection of SCHUNK standard products that are adapted for direct use with the respective robots. Further technical data and usable accessories for the individual Plug & Work components are therefore included in the product information for the respective SCHUNK standard components.

Plug & Work Portfolio Universal Robots – Changing

Plug & Work Portfolio Universal Robots

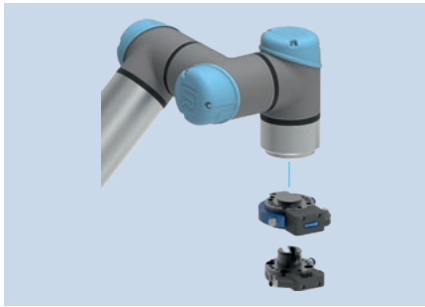

Technical data

Description		EOA-UR3510-SHK-050-E08-000	EOA-UR3510-SHA-050-E08-000
ID		1334788	1334789
Function		Changing	Changing
Robot compatibility		UR 3/5/10/16	UR 3/5/10/16
Standard components		SHS 50	SHS 50
Weight	[kg]	0.35	0.14
Recommended workpiece weight	[kg]	11	11
Max. dynamic bending moment Mx/ My	[Nm]	75	75
Max. dynamic bending moment Mz	[Nm]	135	135

① You can find more technical values in the catalog chapter for the respective standard component.

Main view EOA-UR3510-SHK-050

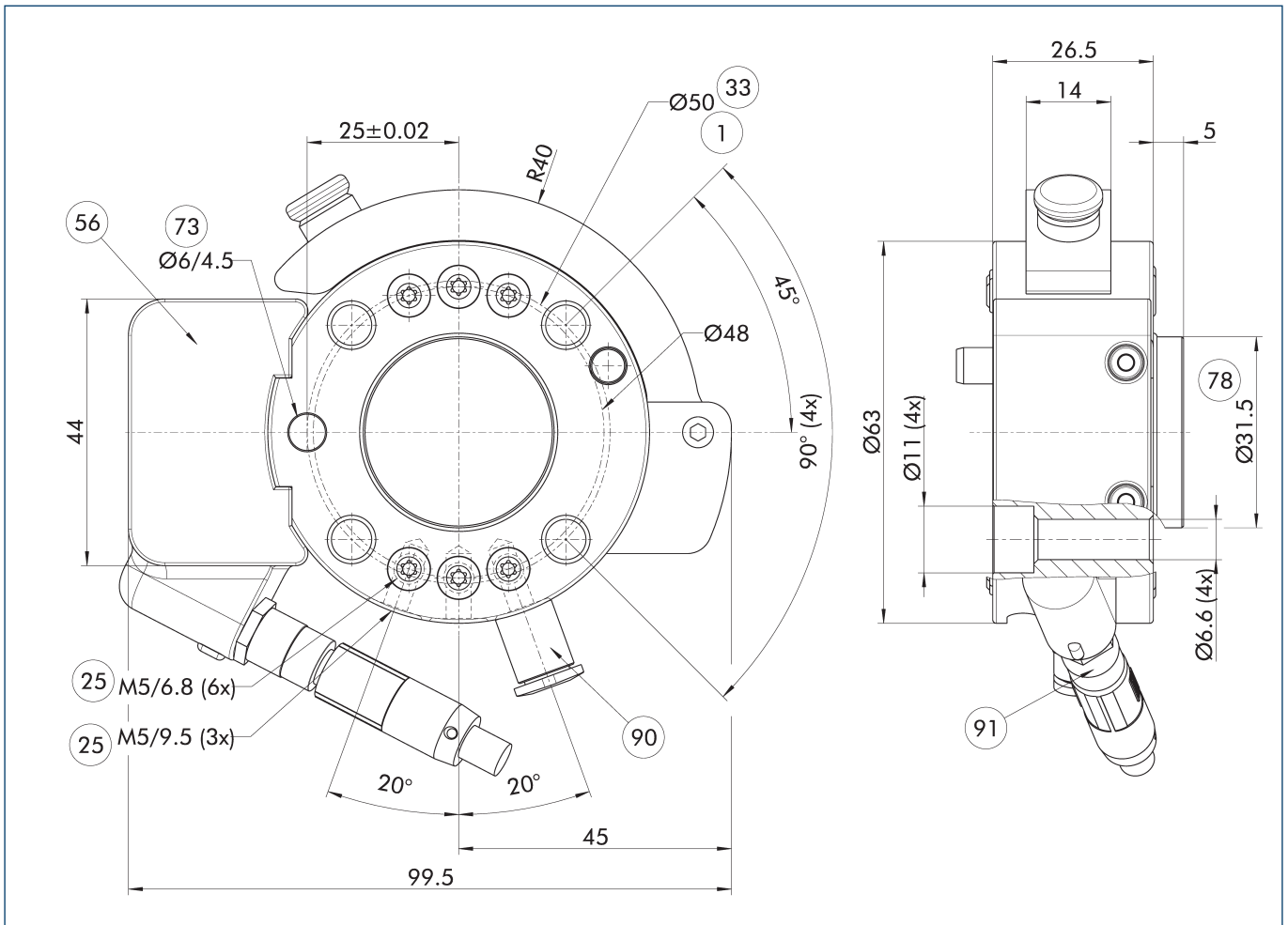

- | | |
|--------------------------------------|---------------------------|
| ① Robot-side connection | ⑦③ Fit for centering pins |
| ②⑤ Pneumatic feed-throughs | ⑦⑧ Fit for centering |
| ③③ DIN ISO-9409 bolt circle | ⑨⑩ Air connection |
| ⑤⑥ Included in the scope of delivery | ⑨① Electrical connection |

Plug & Work Portfolio Universal Robots – Changing

Plug & Work Portfolio Universal Robots

Main view EOA-UR3510-SHA-050

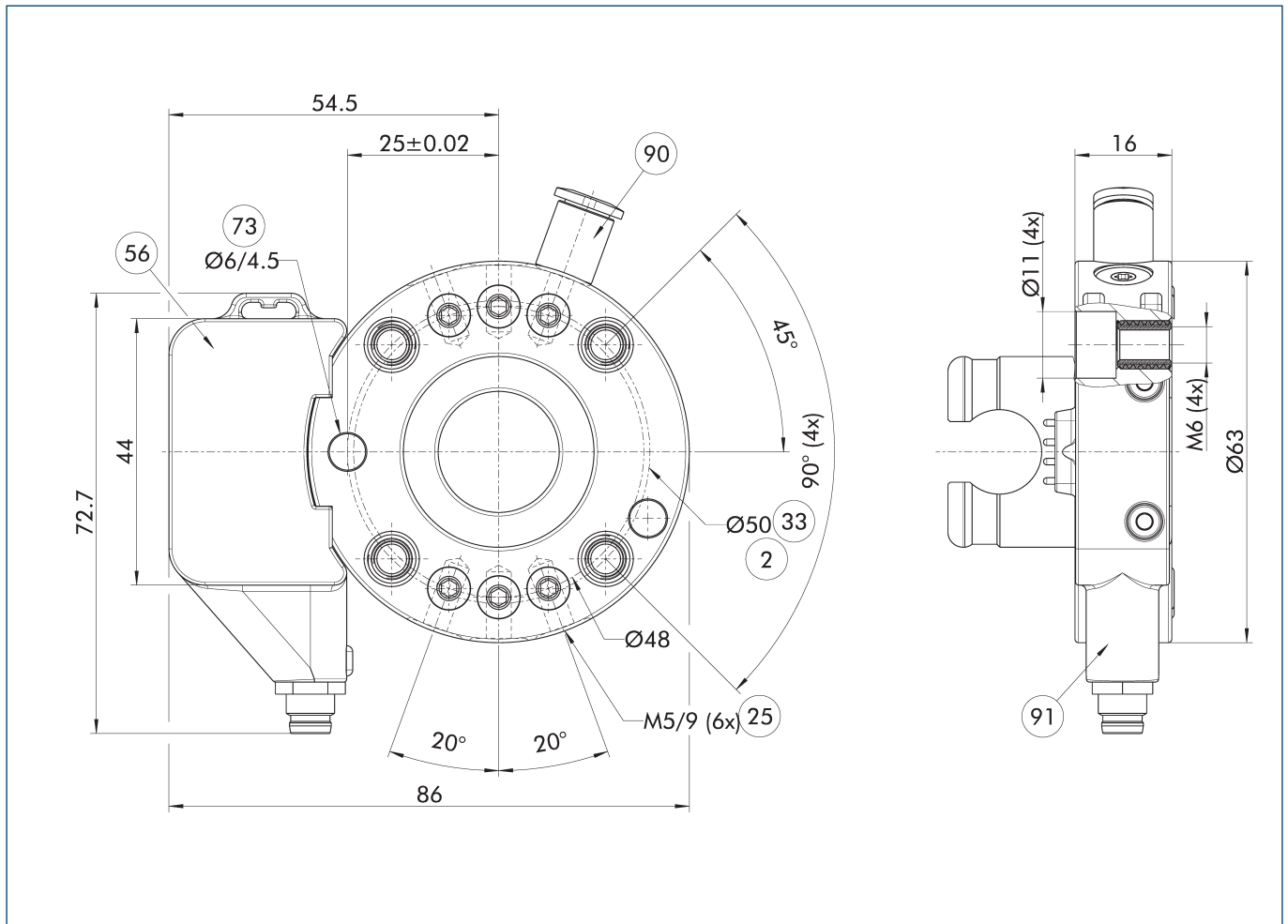

- | | |
|--------------------------------------|---------------------------|
| ② Tool-side connection | ⑦③ Fit for centering pins |
| ②⑤ Pneumatic feed-throughs | ⑨① Air connection |
| ③③ DIN ISO-9409 bolt circle | ⑨① Electrical connection |
| ⑤⑥ Included in the scope of delivery | |



SCHUNK GmbH & Co. KG
Spann- und Greiftechnik

Bahnhofstr. 106 - 134
D-74348 Lauffen/Neckar
Tel. +49-7133-103-0
Fax +49-7133-103-2399
info@de.schunk.com
schunk.com

Folgen Sie uns | *Follow us*

